

LT1 Lambda Transmitter



Table of Contents

1	Important Information about the Manual	5
1.1	Validity of these Instructions	5
1.2	Standards, Directives and Approvals	6
1.3	Glossary	6
2	General Safety Instructions	7
2.1	For Your Safety	7
2.1.1	Explanation of the Symbols in the Safety Notes	7
2.1.2	Proper Use - Conditions of Use	8
2.1.3	Permissible Users	9
2.1.4	Safety Equipment/Safety Measures	10
2.1.5	Protection Against Emissions from Gas Carrying Channels	10
2.1.6	Important Notes on Shutdown/Return to Service	11
2.1.7	Environmental Protection, Waste Disposal	11
3	General Description	12
3.1	System Overview	12
3.2	Labelling	13
4	Technical Description	14
4.1	Components	14
4.1.1	Lambda Probe LS1	15
4.1.2	Construction and Terminal Assignment	16
4.1.3	Designation and Assignment of the Connections	18
4.1.4	Shutdown and Waste Disposal	19
5	Operating Control and Displays	20
5.1	Processor Board Multi-Function Pushbutton	20
5.1.1	LED-Display	21
5.1.2	Multi-function Pushbutton	22
5.1.3	Automatic Checking using Test Gas (optional)	22
5.2	Monitor Output	23
5.3	Digital Inputs	23
5.4	Remote-Display-Software (Option)	24
5.5	Display and Operating Unit	24
5.5.1	Menu Functions	25
5.5.2	Variable parameters at operating and customer level	31
6	Operation	33
6.1	Starting O ₂ measurement	33
6.2	Setting the Language for the Display and Operating Unit (optional)	33
6.3	Interruption of Operation	33
6.4	Decommissioning	33
6.5	Practical Information	34
6.5.1	Damping for Jumping Display Values	34
6.5.2	Measurement in Wet and Very Contaminated Exhaust Gas	35
6.5.3	Wet/Dry Measurement Deviations, Conversion Table	36
6.5.4	Measurement Value Deviations due to Changes in Pressure	37
7	Maintenance	38

Table of Contents

7.1	Maintenance Schedule	38
7.1.1	Check Measurement	38
7.1.2	Replace Wear Parts	38
7.1.3	Maintenance Tasks	38
7.1.4	Draining off the Condensate	40
7.1.5	Replacing the Pump Protection Filter	41
7.1.6	Removing the Measuring Gas Pump	43
7.1.7	Installing the Measuring Gas Pump	44
7.1.8	Dismantling the Pump Head	45
7.1.9	Cleaning the Pump Head	46
7.1.10	Determining the Pump Operating Time	46
7.2	Replacing the Probe	47
7.2.1	Removing the Probe	48
7.2.2	Installing the Probe	49
7.2.3	Removing the GED	50
7.2.4	Installing the GED	51
7.2.5	Checking and Calibrating the Probe	52
7.2.6	Resetting the Probe Heating Controller to the Basic Value	53
7.2.7	Completion of Probe Record Card	54
7.2.8	Activating Service Warnings	54
8	Faults/Warnings	55
8.1	Display via Processor Board	55
8.2	Warnings	55
8.3	Faults	57
8.3.1	Internal Electronics Faults	57
8.3.2	Resetting Faults/Warnings	57
8.3.3	Cause of Fault	59
8.3.4	Information on the Faults	62
8.4	Troubleshooting	63
8.4.1	Replace the Processor Board	63
8.4.2	Checking the Tightness of Seal of the Lambda Probe LS1	64
8.4.3	Check the Measuring Gas Hose for Leaks	65
8.4.4	Change the Quantity of Calibrating Gas	65
8.4.5	Change PT100	66
8.4.6	Replacing the "Critical Nozzle"	67
8.4.7	Cleaning the Sampling Attachment with the Sintered Metal Filter	68
8.4.8	Check sample gas extraction device (GED) for permeability	69
8.4.9	Clean the PIF Preliminary Filter	70
8.4.10	Checking the Probe Heating System	71
8.4.11	Checking the GED Heating System	71
8.4.12	Checking the Preliminary Filter Heating System	72
8.4.13	Removing the GED Heating System	73
8.4.14	Installing the GED Heating System	74
8.4.15	Removing the Preliminary Filter Heating System	75
8.4.16	Installing the Preliminary Filter Heating System	76
9	Appendix	77
9.1	Connection Diagrams	77
9.2	Basic Printed Circuit Board	82

Table of Contents

9.3	Analogue Output Card	86
9.4	Other Details, Dimensions	87
9.5	Spare Parts	88
9.6	EU Declaration of Conformity	90
9.7	SIL Manufacturer Declaration	92

1 Important Information about the Manual

1 Important Information about the Manual

1.1 Validity of these Instructions

Content of this Operating Manual

This Operating Manual describes the Lambda Transmitter LT1 with all components necessary for O₂ measurement, such as the Lambda Probe LS1, the probe installation fitting, etc.

Accessories and special applications

Information on accessories and special applications is provided in the booklets supplied with the particular systems. This information can be obtained from the manufacturers, at the Wall-dorf address.

This Operating Manual explains the functioning, mounting, installation, maintenance and operation of the Lambda Transmitter LT1. Other booklets, such as Product Information for example, provide further information but must never be used as a substitute for this Operating Manual.



CAUTION!

Always read the Operating Manual before starting work!
Please adhere strictly to all warnings/safety instructions!

For particular tasks, for example electrical installation, specialised knowledge is required. These tasks may only be carried out by suitably qualified personnel. See chapter 2.1.3 *Permissible Users*.

Validity

Our products undergo constant redevelopment. However, we make every effort to ensure that the Operating Manual is accurate and relevant to individual applications.

All previous editions are rendered obsolete on publication of an updated and corrected new edition.

On the last page you will find the current version number of this Operating Manual and the corresponding order number.

1 Important Information about the Manual

1.2 Standards, Directives and Approvals

The Lambda Transmitter LT1 complies with the following standards and rules:

European directives:

2014/30/EU	EMC - Directive
2014/35/EU	Low Voltage Directive
2011/65/EU	RoHS

Harmonised European standards:

DIN EN 61326-1: 2013-07
DIN EN 61010-1: 2011-07
DIN EN 60730-1: 2012
DIN EN 61508: 2011, parts 1-7

SIL 1	DIN EN 61508:2011 only in combination with the fully automatic adjustment unit and corresponding parameterisation (see document DLT6040):
-------	---

NOTICE

Respect the national safety regulations and standards.

1.3 Glossary

Abbreviations

GED XXX	Gas extraction device XXX
PCB	Probe connection box
PIF	Probe installation fitting
Li	Limit values
IP	Protection class for example IP54

2 General Safety Instructions

2 General Safety Instructions

2.1 For Your Safety

2.1.1 Explanation of the Symbols in the Safety Notes

The following symbols are used in this document to draw the user's attention to important safety information. They are located at points where the information is required. It is essential that the safety information is observed and followed, and that applies particularly to the warnings.



DANGER!

This draws the user's attention to imminent danger. If it is not avoided, it will result in death or very serious injury. The plant including its surroundings could be damaged.



WARNING!

This draws the user's attention to the possibility of imminent danger. If it is not avoided, it may result in death or very serious injury. The plant including its surroundings could be damaged.



CAUTION!

This draws the user's attention to the possibility of imminent danger. If it is not avoided, it may result in minor injuries. The plant including its surroundings could be damaged.

NOTICE

This draws the user's attention to important additional information about the system or system components and offers further tips.

The safety information is incorporated into the instructions.

Thus, the operator is requested to:

- 1 Comply with the accident prevention regulations whenever work is being carried out.
- 2 Do everything possible within his control to prevent personal injury and damage to property.

2 General Safety Instructions

2.1.2 Proper Use - Conditions of Use

Application

The LT1 Lambda Transmitter is an O₂ measuring instrument for the continuous measurement of O₂ concentration in non-combustible gases in the super-stoichiometric domain, in conjunction with the LS1 Lambda Probe.

Suitable for gas measurements with a small proportion of combustible components (< 10,000 ppm), for example in flue gases of combustions systems.

Admissible fuels:

- Non-interacting gaseous hydrocarbons
- Light oil
- Coal
- Biomass (wood)

NOTICE

Direct measurements in combustion gases are not possible.

If the system is to be used in some other way, and if the instrument's functionality in this application cannot be unambiguously assessed, the manufacturer should be contacted in advance.

Prerequisites

It is assumed that facility planning, assembly, installation, commissioning, maintenance and service works are carried out by sufficiently trained personnel, and these works are supervised by qualified specialists.

Correct handling

Special attention must be paid to the following:

- The application must conform to the technical data and the specifications regarding authorised use, assembly, connection, environmental and operational conditions (derived from the job documentation, the instrument's user information, rating plates etc), and to the documentation supplied.
- The local regulations and facility-specific and technical hazards must be noted and followed.
- All steps necessary to protect the equipment, e.g. during transport, storage, maintenance and inspection, should be carried out.

2 General Safety Instructions

2.1.3 Permissible Users

Qualified personnel

The persons responsible for safety must ensure that

- All work on the system components is performed by qualified personnel. Qualified personnel are persons who, by virtue of their education, training, experience or instruction, and their knowledge of the relevant standards, specifications, accident prevention regulations and properties of the systems, have been authorised by the person(s) responsible for operator and system safety to undertake these activities. It is imperative that these persons are able to detect and avoid possible hazards in good time.

Specialist personnel are those who fulfil the requirements set out in DIN VDE 0105 or IEC 364 or directly equivalent standards such as DIN 0832.

- The Instruction Manual supplied with the system and the relevant order documentation are available to these persons for all work carried out and these persons comply with this documentation in order to prevent any danger or damage.

User groups

It is assumed that the Lambda Transmitter LT1 is handled by two groups of users:

- a Service technicians from LAMTEC or their OEM customers, or qualified customer personnel:
qualified technicians/engineers with very good knowledge of the system.
- b Operators, customer installation personnel, technicians for measuring and control systems, electrical and electronic systems, familiarised with the system.

2 General Safety Instructions

2.1.4 Safety Equipment/Safety Measures

Hazards from electrical equipment

The LT1 Lambda Transmitter and the LS1 is equipment for use in industrial electrical power installations. Always switch off the power when working on mains connections or mains voltage. If shrouding (for electrical safety) has been removed, reattach it before switching on the power supply again. Damage to health or equipment may result from improper use or improper handling.

NOTICE

To avoid damage, always observe the respective security notices.

Preventive measures for improving operating safety

If the LT1 is used in conjunction with control and monitoring technology, the operator must ensure that any breakdown or failure of the LT1 device does not cause inadmissible damage or dangerous operating states. To avoid faults which could cause direct or indirect personal or material damage, the operator must ensure that:

- the responsible maintenance personnel can be reached at any time and as quickly as possible
- the maintenance personnel are trained to correctly respond to faults with the LT1 Lambda Transmitter and the associated malfunctions
- in the case of doubt, the faulty equipment can be switched off immediately
- A switch-off does not lead to direct follow-up problems.

Avoiding consequential damages

To avoid consequential damages in the event of failure, which could cause direct or indirect personal or material damage, the owner must ensure that qualified personnel can assess the faults and initiate appropriate measures to tackle them.

2.1.5 Protection Against Emissions from Gas Carrying Channels

The Lambda Transmitter LT1 is attached directly to the gas-carrying duct by the probe installation fitting (PIF) and the mating flange. If the LS1 Lambda Probe or the probe installation fitting (PIF) is removed, the operating system, especially if pressurised, can cause corrosive and/or hot gas to escape from the duct through the flange, causing severe injury to the operator if the operator is unprotected and if appropriate safety precautions have not first been taken.

WARNING!

Discharge of hot, corrosive gases !

In the event of high pressure and temperatures higher than 200 °C | 392 °F in the gas duct, gas escapes when the probe or the probe installation fitting (PIF) is removed.

- ▶ Switch OFF the application before opening.
 - ▶ Wear protective clothing and a protective mask.
 - ▶ Affix appropriate warnings near by.
 - ▶ Close aperture immediately after finishing work.
-

2 General Safety Instructions

2.1.6 Important Notes on Shutdown/Return to Service

The Lambda Transmitter and the Lambda Probe form a high quality electronic system. Treat them with care at all times, including during shut-down, transport and storage.

Shut-down

NOTICE

Do not switch the Lambda Transmitter off as long as the Lambda Probe is mounted; including when the relevant facility has been shut down. Residual gases cause corrosion and may damage system parts.

- ▶ Do not store the instruments outdoors without protection!
Always store in a dry place, if possible in the original packaging.
 - ▶ When dismantling, protect cable ends and plugs against corrosion and dirt. Corroded plugs may cause malfunction.
 - ▶ If possible, transport in the original packaging.
-



WARNING!

Danger of burns!

If the probe is operated when removed, there is a danger of burns on the probe housing.

- ▶ Never lay the probe on flammable material and heat it up.
 - ▶ Wear protective gloves.
-

Return to service

According to chapter 6 *Operation*.

2.1.7 Environmental Protection, Waste Disposal

The design of Lambda Transmitter and Probe is also based on environmental considerations. The modules can easily be separated and sorted into distinct types, and recycled accordingly.

3 General Description

3 General Description

3.1 System Overview

The Lambda Transmitter LT1 is a universal, microprocessor-based measuring device for directly measuring the O₂ concentration in the super-stoichiometric range ($\lambda > 1$) in combination with the proven Lambda Probe LS1.

The Combination Probe KS1 can be connected for measuring combustible Gas constituents (CO/H₂).

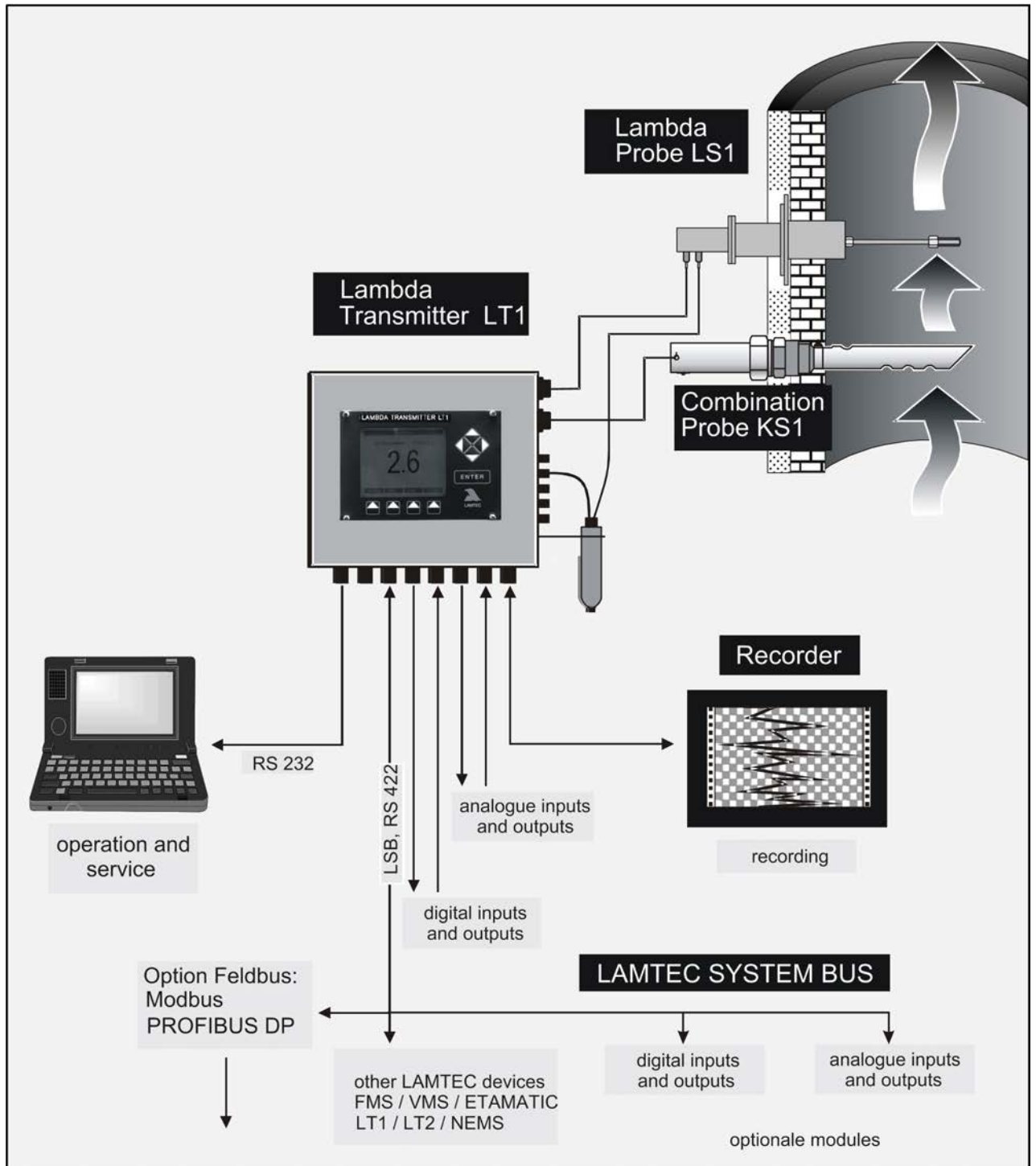

3 General Description

3.2 Labelling

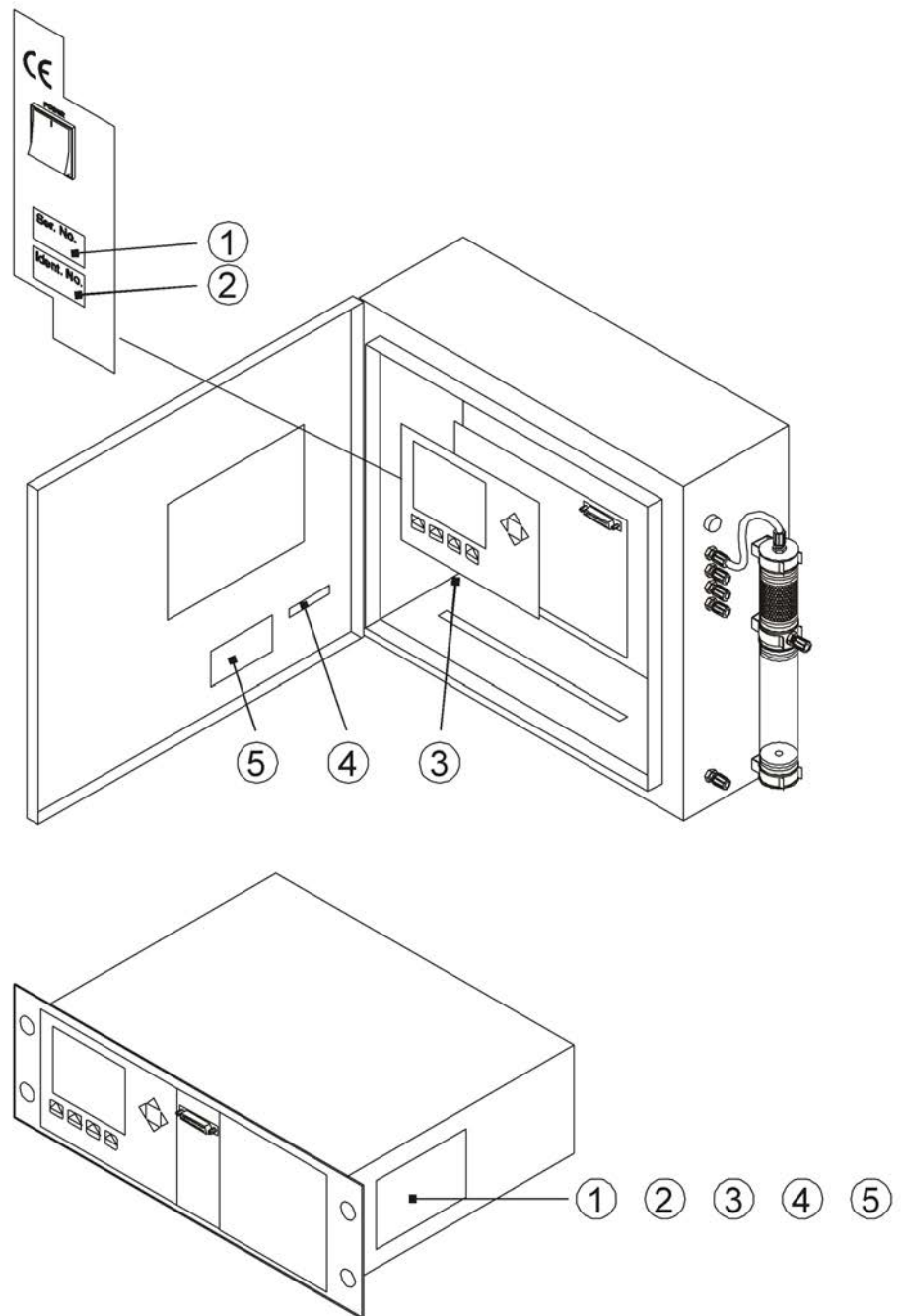

- 1 Serial number
- 2 ID number
- 3 Voltage (only for special voltages)
- 4 Performance test no.
- 5 Device configuration:

4 Technical Description

4.1 Components

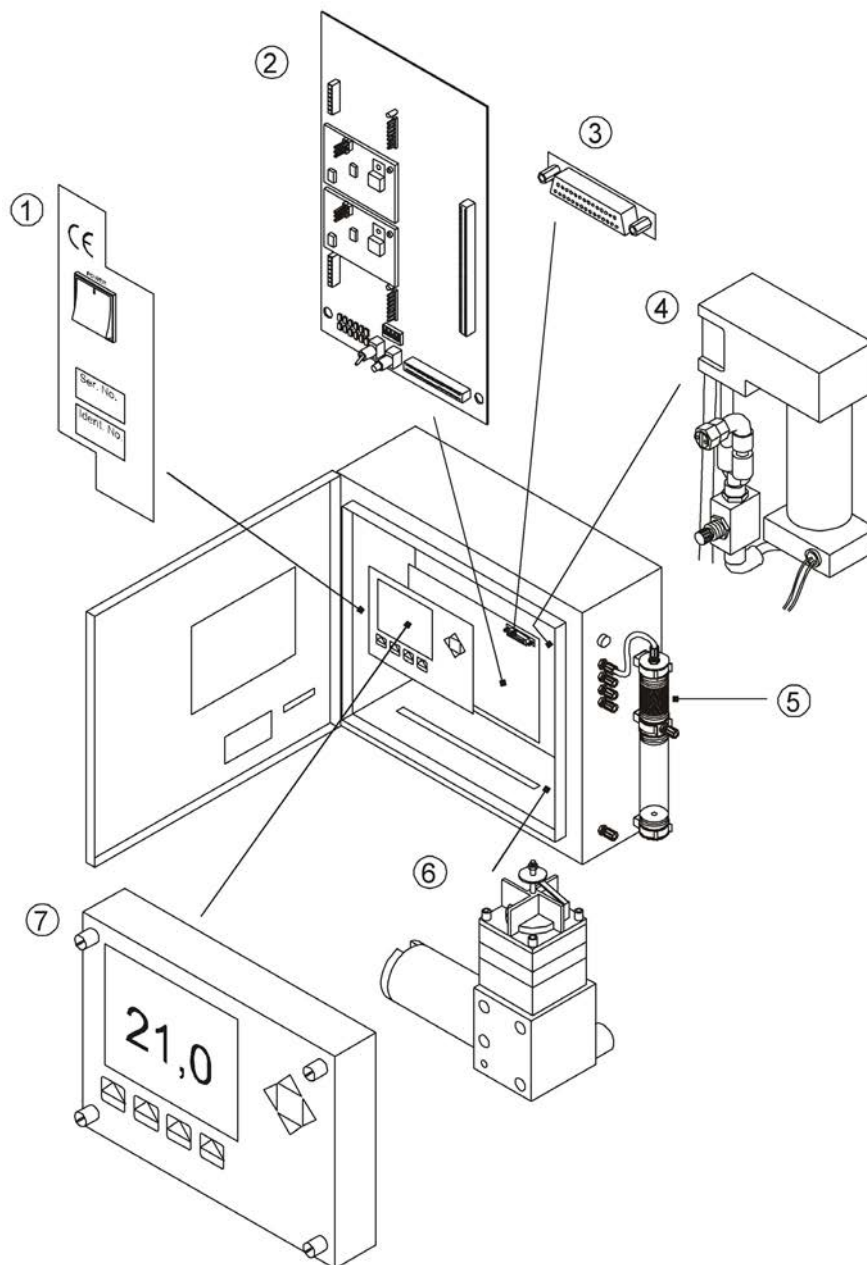

- 1 On/off switch
- 2 Processor board
- 3 PC interface
- 4 Automatic calibrating device (optional)
- 5 Pump protection filter with condensate tank
- 6 Measuring gas pump
- 7 Display and operating unit (optional)

4 Technical Description

4.1.1 Lambda Probe LS1

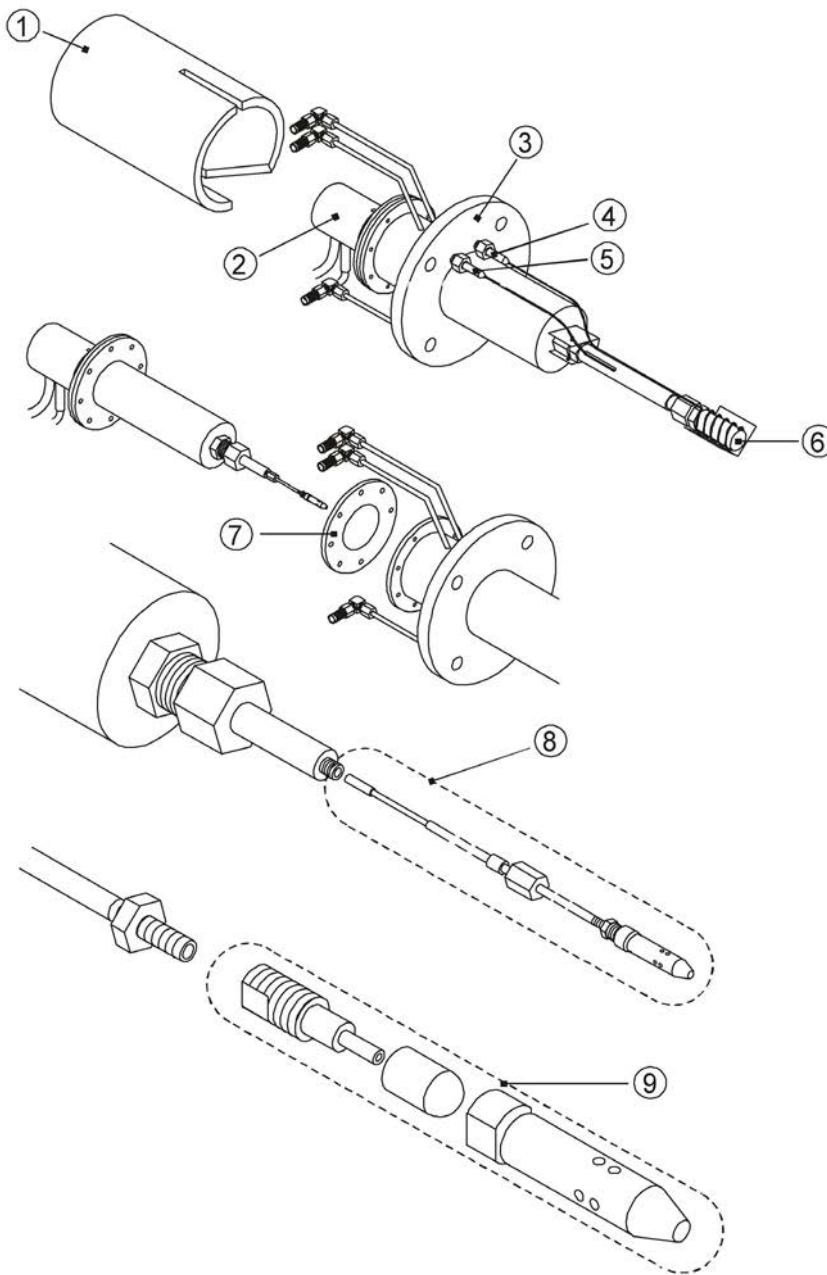

- 1 Insulating moulding (external)
- 2 Lambda probe LS1
- 3 Probe installation fitting (PIF)
- 4 Preliminary filter heating system (optional)
- 5 GED heating system (optional)
- 6 Preliminary filter PIF
- 7 Flange gasket LS1/PIF
- 8 Gas extraction device (GED)
- 9 Sampling filter

4 Technical Description

4.1.2 Construction and Terminal Assignment

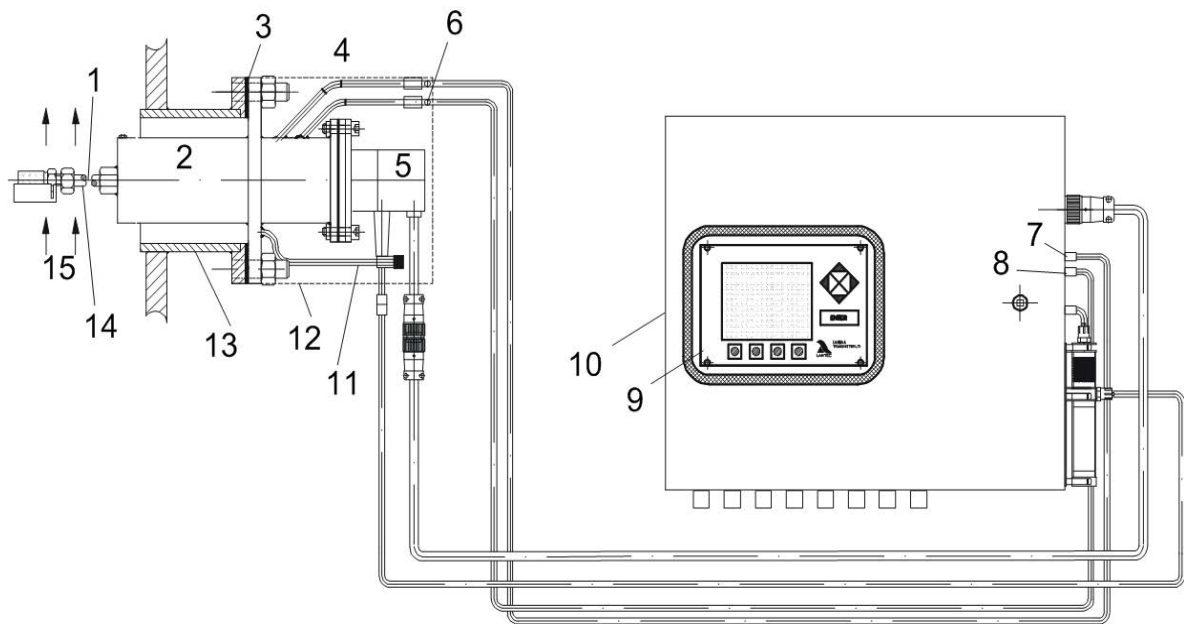

Fig. 4-1 Mounting principle with integral measuring gas pump and calibration unit into LT1 for installation under roof.

- 1 Measurement gas temperature > Water as well as acid dew point
Max. 400 °C | 752 °F, the Probe Installation Fitting (PIF) must be set back when the measuring gas temperature is high
- 2 Probe Installation Fitting (PIF) type 655R0083 ... R1183
- 3 Flange seal for counter flange DN100 PN16, 3 mm | 0.12" in graphite type 655P4213
- 4 Connection for pressure sensor
- 5 Lambda ProbeLS1 type 650R0031/0034
- 6 Connection calibration gas
- 7 Pressure sensor
- 8 Connection calibration gas LT
- 9 Display and operating unit (Option)
- 10 Lambda Transmitter LT1 type 657R002 with integral measuring gas pump and automatic calibration unit (Option) and display and operating unit
- 11 Measuring gas feedback - seal with dummy plug
- 12 Insulation for LS1 and probe installation fitting (PIF) type 657P0100
- 13 Counter flange type 655R0183 /R0185
- 14 Gas extraction device (GED) with sintered metal pre-filter
- 15 Measuring gas

NOTICE

The distance LS1-LT1 must be < 10m | 32.81 ft !

The O₂ measurement is done in the probe.

4 Technical Description

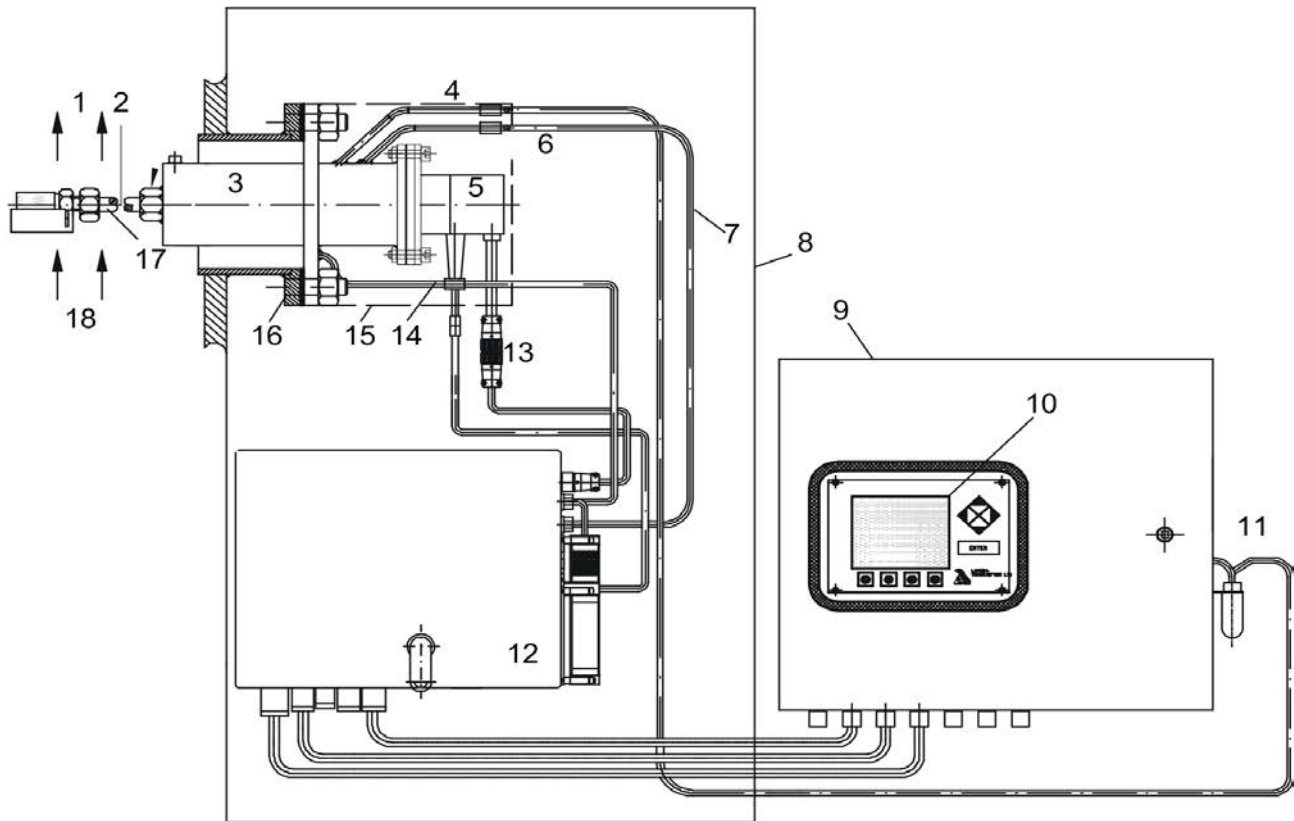
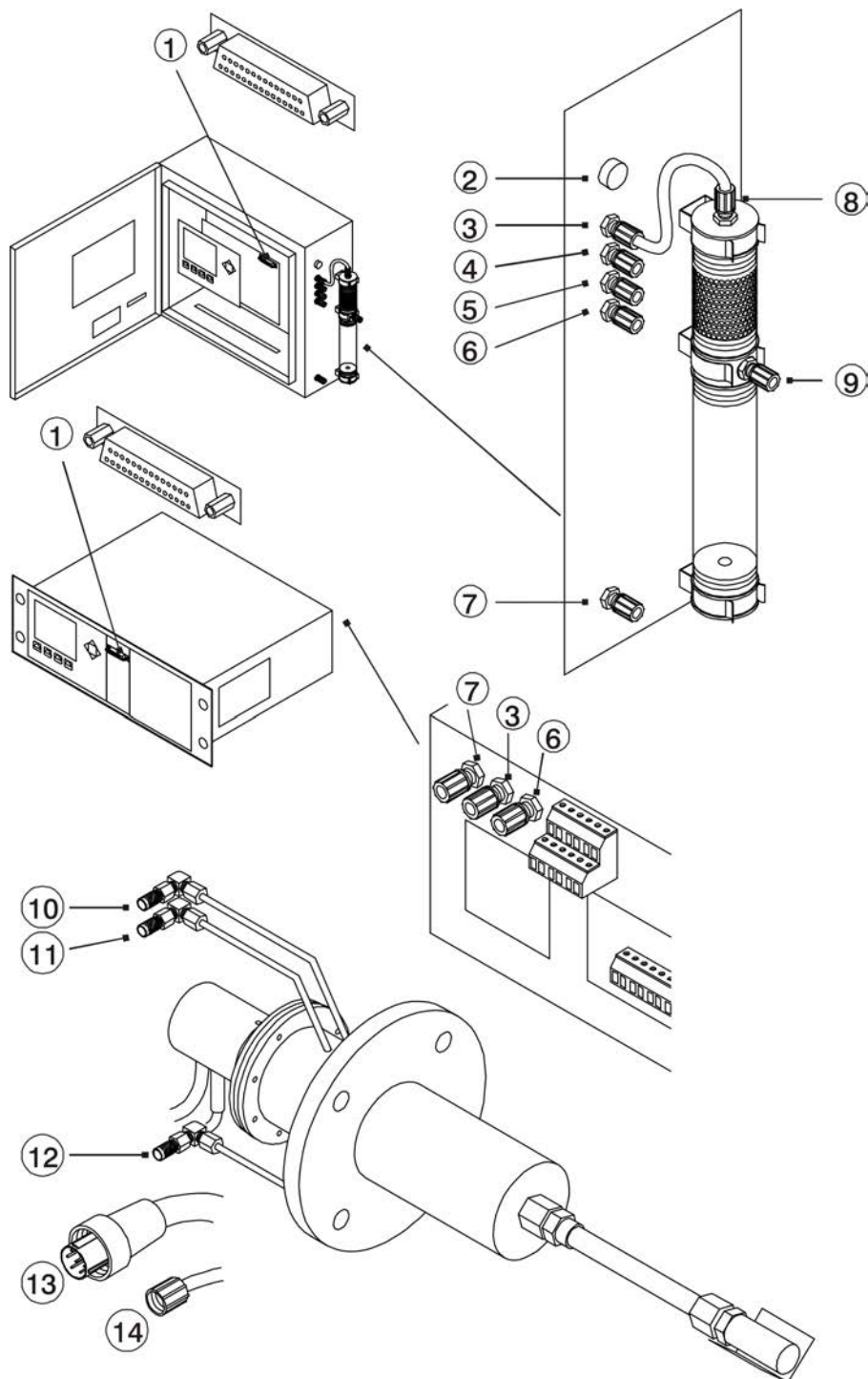

Fig. 4-2 Mounting principle of the with external pump and calibration device into PCB

- 1 Flue gas duct
- 2 Measurement gas temperature > Water as well as acid dew point
Max. 400 °C | 752 °F, the Probe Installation Fitting (PIF) must be set back when the measuring gas temperature is high
- 3 Probe installation fitting (PIF) type 655R0083 ... R1183
- 4 Pressure sensor connection
- 5 Lambda Probe LS1 type 655R0031/0034
- 6 Calibrating gas connection
- 7 Calibration gas pipe
- 8 Transmitter protection box
- 9 Lambda Transmitter LT1 type 657R002 design external measuring gas pump, display and operating unit
- 10 Display and operating unit (Option)
- 11 Condensate trap/Connection pressure sensor LT
- 12 Probe connection box with measuring gas pump and calibration unit
- 13 Electric connection with plug
- 14 Measuring gas feedback
- 15 Insulation for LS1 and PIF type 657P0100
- 16 Counter flange type 655R0183/R0185
- 17 Gas Extraction Device (GED) and protecting tube with sintered metal pre-filter
- 18 Measuring gas

4 Technical Description

4.1.3 Designation and Assignment of the Connections



Lambda Transmitter LT1	Connection to: Lambda Probe LS1 / PIF	Others
1 PC interface		Remote display software
2 Connection for probe connector	13 Connection for LS1 connector	
3 Inlet measuring gas pump (connected to 8)		
4 Calibrating gas for probe	11 Calibrating gas (air)	

4 Technical Description

Lambda Transmitter LT1	Connection to: Lambda Probe LS1 / PIF	Others
5 Calibrating gas inlet		Calibrating gas (air)
6 Pressure sensor	10 Pressure sensor	
7 Measuring gas outlet	12 Exhaust gas return path ⁽¹⁾	
8 Filter output (connected to 9)		
9 Hose connection LS1	14 Measuring gas outlet	

⁽¹⁾ If the measuring gas return path is not laid, this is to be sealed with a blanking plug.

4.1.4 Shutdown and Waste Disposal

The design of Lambda Transmitter and Probe is also based on environmental considerations. The modules can easily be separated and sorted into distinct types, and recycled accordingly.

5 Operating Control and Displays

5 Operating Control and Displays





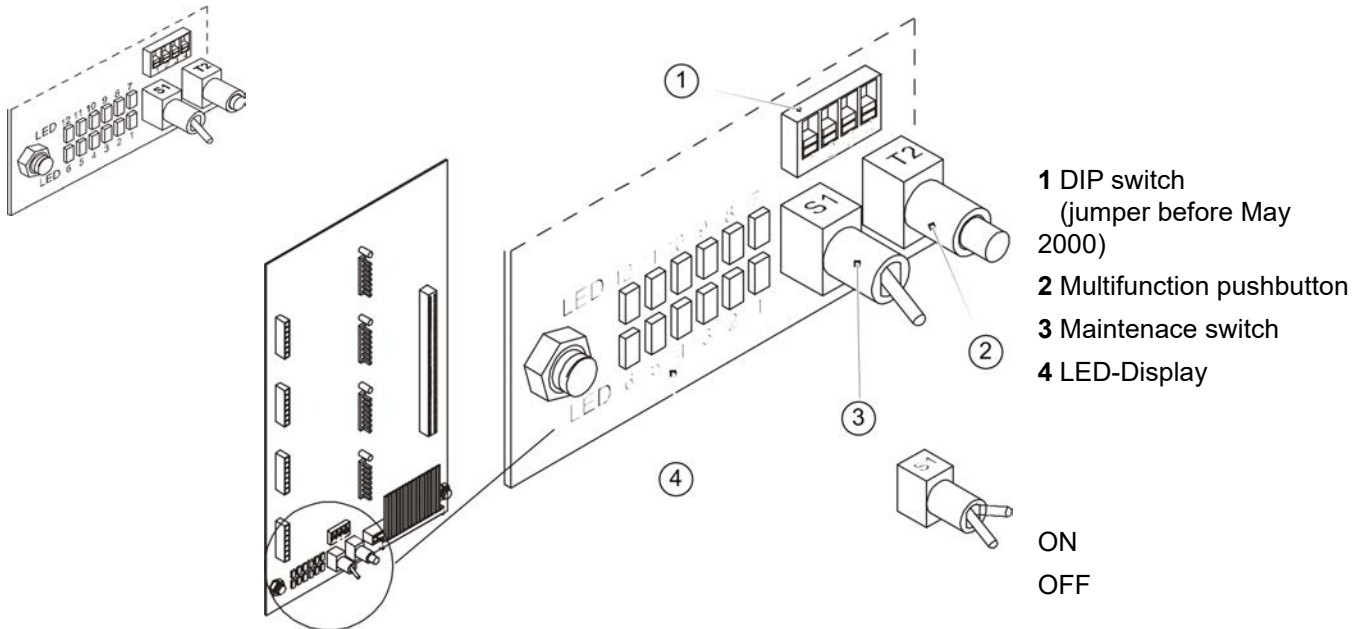







5.1 Processor Board Multi-Function Pushbutton

All basic functions can be performed using the multi-function pushbutton and maintenance switch.



5 Operating Control and Displays

5.1.1 LED-Display

Legend: LED		is off		is flashing		is illuminated
LED1		Maintenance				
						Normal operation
						Maintenance mode active
LED2		---				
LED3		---				
LED4						Heating system monitoring facility
						Heating control active
						Heating with fixed voltage
LED5						Operating mode display
						Calibration
						Measurement
LED6						Status display
						Operation
LED12						Warning/fault indicator
						No warning/fault
						At least 1 fault present
						At least 1 warning present

5 Operating Control and Displays

5.1.2 Multi-function Pushbutton

Function:	Operate push-button:
Switch from the warning / fault displayed	briefly
Reset the warning / fault displayed	3 s. *
Quick-start measuring gas pump, abort cold-start	3 s/6 s**
Initiate calibration (in measuring mode)	3 s/6 s**

* Some warnings/faults cannot be reset if the fault is still present or the routine continues
** If more than one warning/fault is present, the pushbutton must be pressed for 6 seconds.

5.1.3 Automatic Checking using Test Gas (optional)

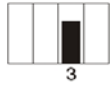
Test gas connection	DIP switch	SW3
Deactivated		ON
Activated		OFF

5 Operating Control and Displays

5.2 Monitor Output

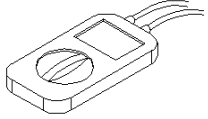

The following measurement values can be interrogated via terminals 31 and 32:

- O₂ measurement value
- Probe voltage
- Probe current

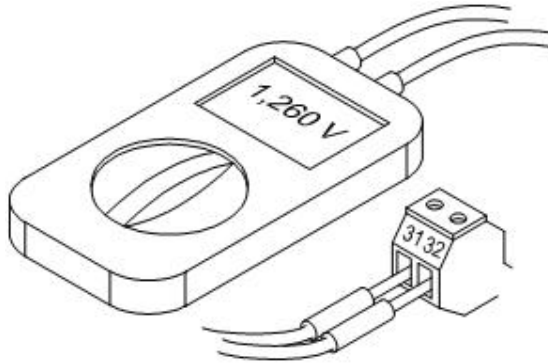

Measurement	Conversion	DIP switch	SW1	SW2
O ₂ measurement value	0...2,5 V -> 0...25% O ₂		OFF	OFF
Probe voltage	0...1,4 V -> 0...1400 mV		ON	OFF
Probe current	0...1 V -> 0...1000 mA		OFF	ON

5.3 Digital Inputs



Input 2, factory setting:
Initiate calibration of the probe

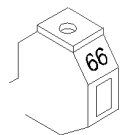

Input 5, factory setting:
Reset fault and warning messages

5 Operating Control and Displays

5.4 Remote-Display-Software (Option)



Instructions are included in the software

5.5 Display and Operating Unit

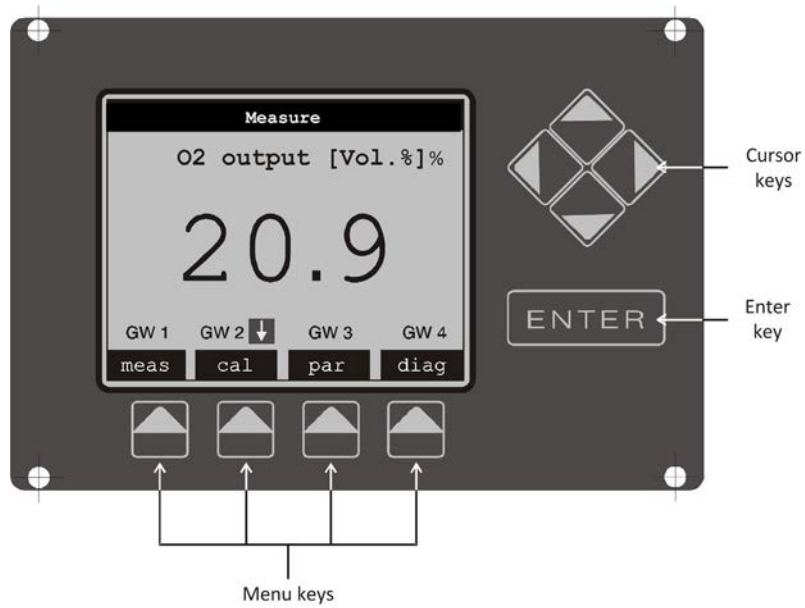

Brightness and contrast: Contrast +:  +  Contrast -:  + 

Brightness +:  +  Brightness -:  + 

Limit values: GW 1  Limit value has not been reached

GW 3  Limit value has been exceeded

NOTICE

The limit values (GW 1 to GW 4) will only be displayed if limit value monitoring has been activated.

Menu keys

meas: measurement
cal: calibration
par: parameter setup
diag: diagnosis

5 Operating Control and Displays

5.5.1 Menu Functions

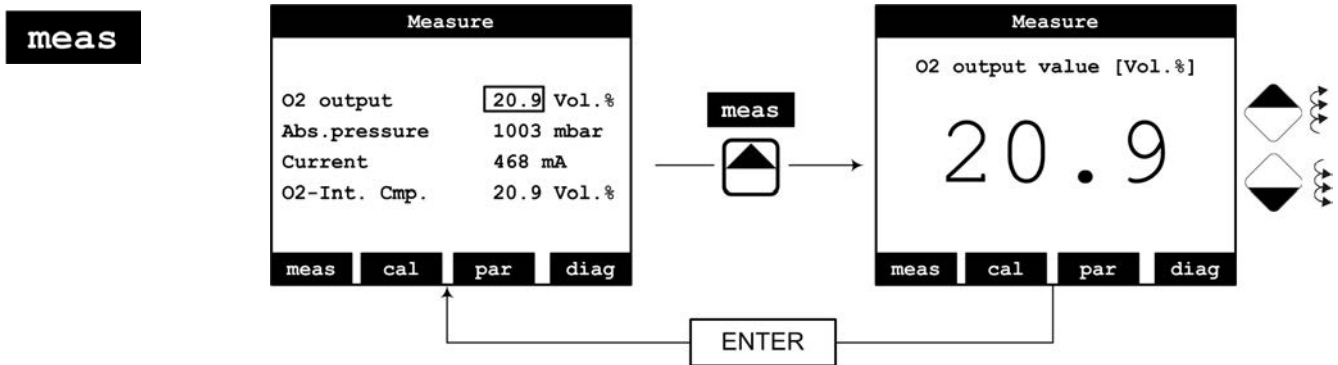

5 Operating Control and Displays

cal

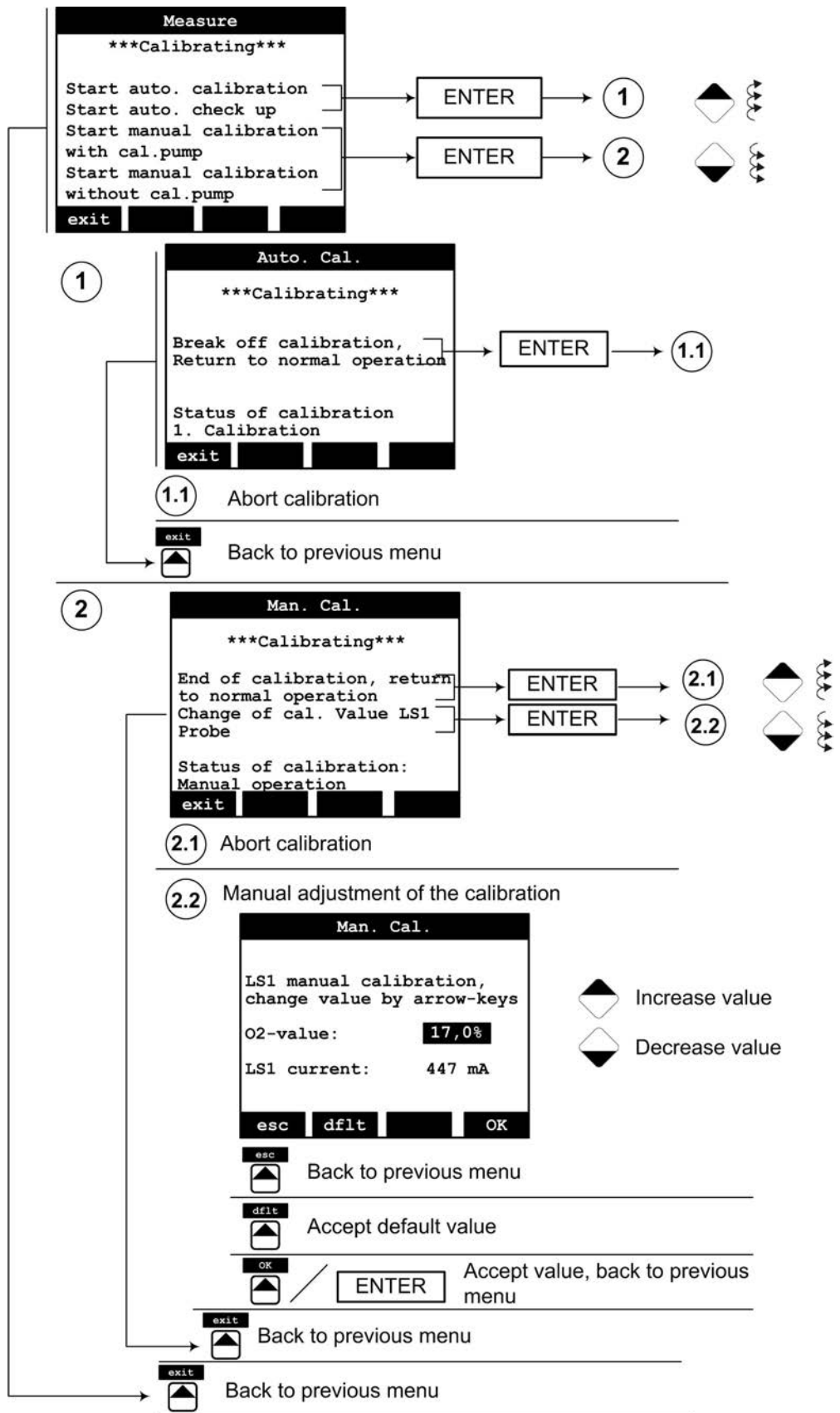

5 Operating Control and Displays

par

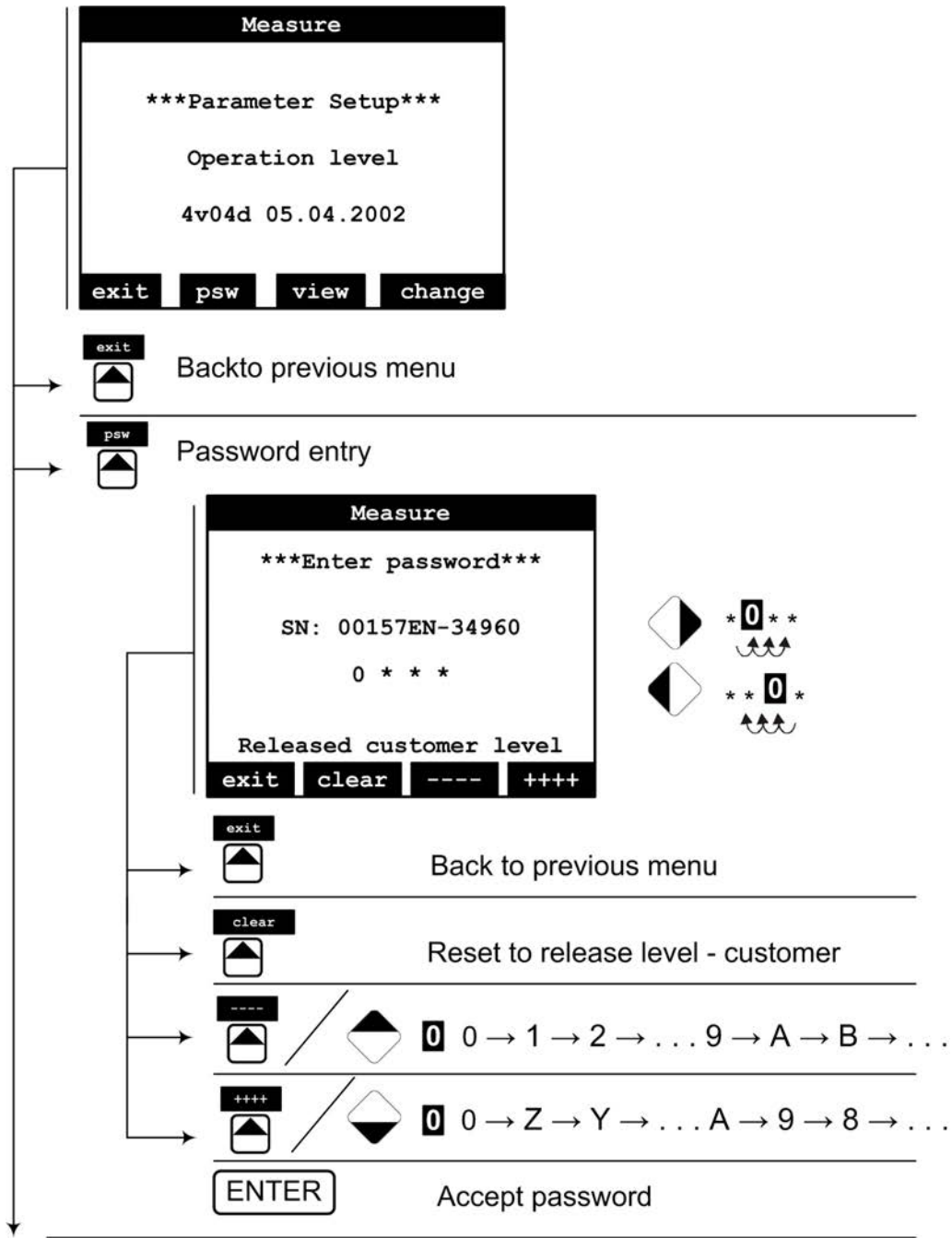

5 Operating Control and Displays

par

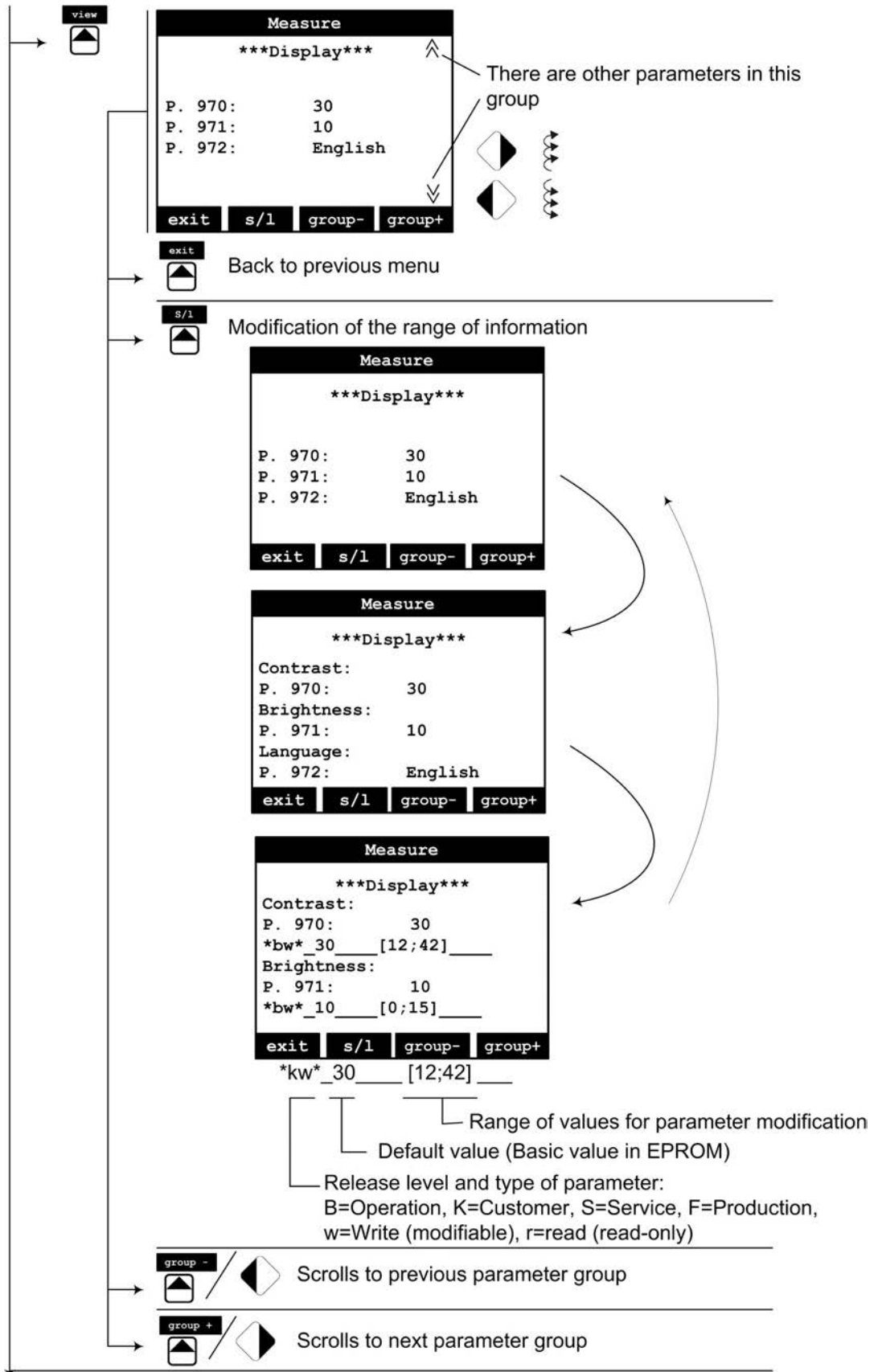

5 Operating Control and Displays

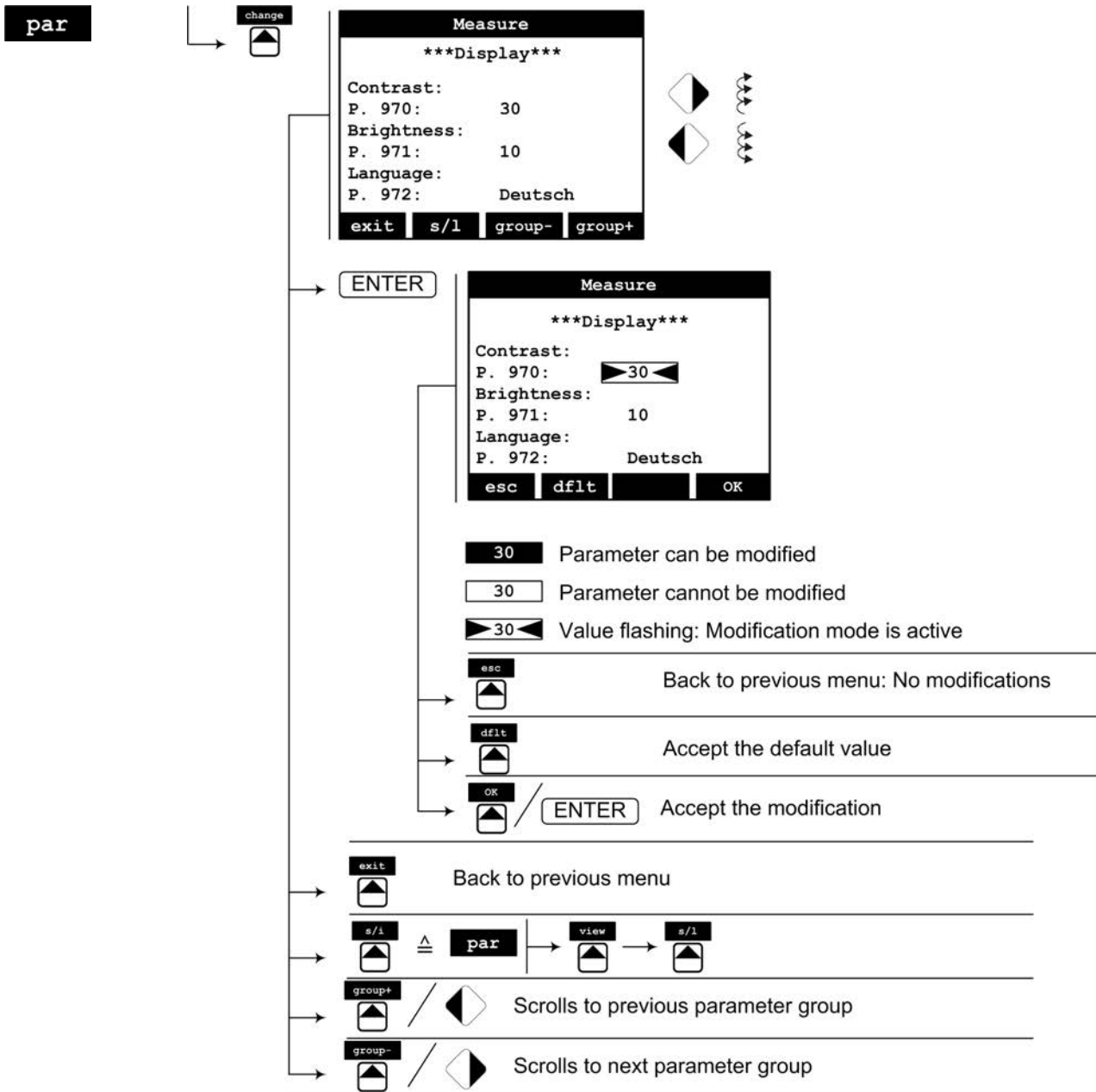

5 Operating Control and Displays

diag

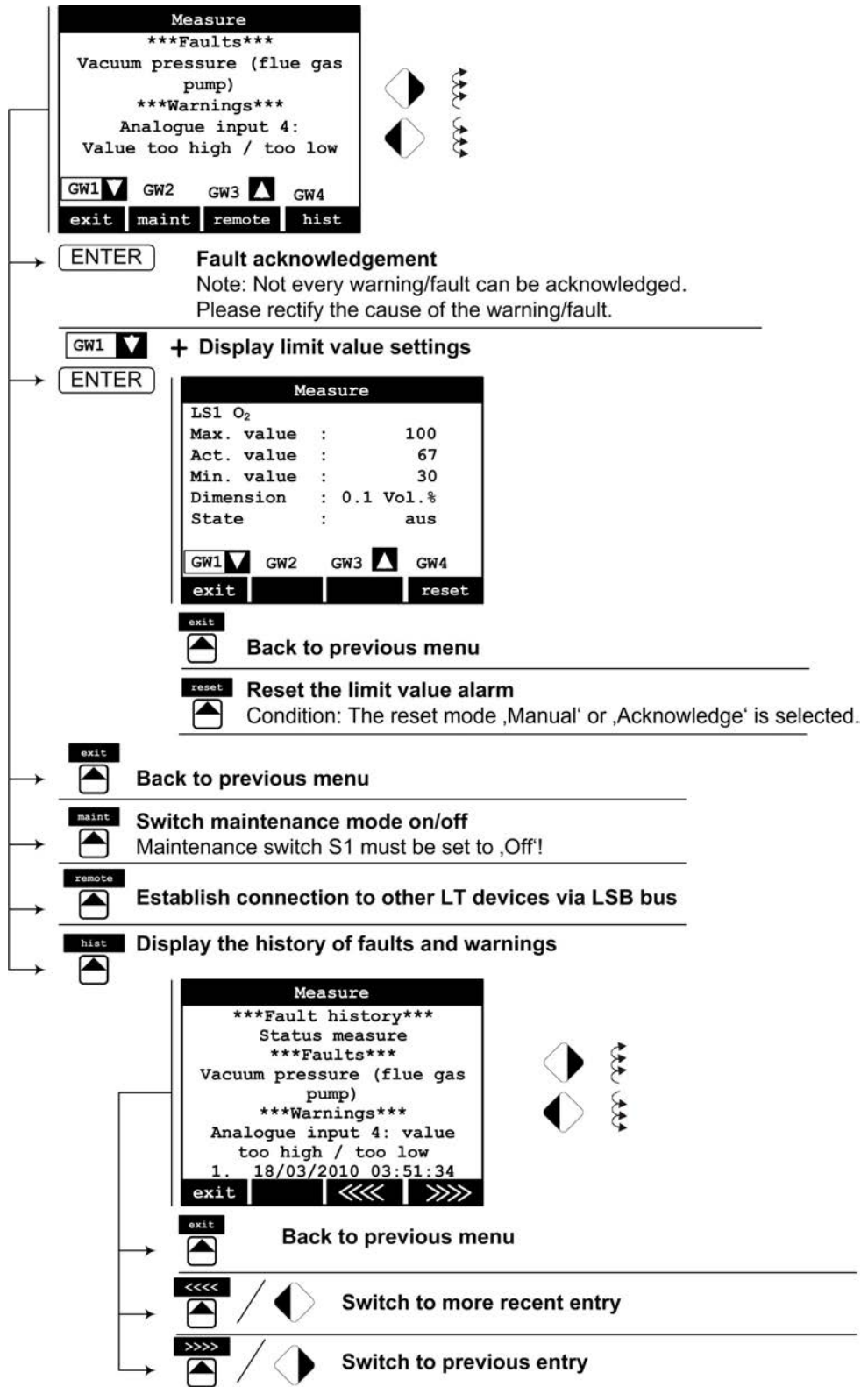

5 Operating Control and Displays

5.5.2 Variable parameters at operating and customer level

Operating level

Measurement values	P 0001 – 0016
Operating data	P 0046 – 0056
Meters and times	P 0070 – 0072
O ₂ -measurement value configuration	P 0360
Measurement value configuration	P 0713 – 0813
Limit values	P 0910 – 0917
Display	P 0970 – 0972
Software version	P 0985 – 0990
BUS interface	P 1301
PID controller	P 1350 – 1357
Status PID controller	P 1381
Parameter CRC 16	P 1490 – 1493

Customer level

Access can only be gained at customer level by entering a password. The factory setting for the customer password is „0000“.

5 Operating Control and Displays

Measurement values	P 0001 – 0016	Measurement value configuration	P 0713 – 0813
Operating data	P 0040 – 0056	Fuel configuration	P 0835
Meters and times	P 0070 – 0072	Limit values	P 0910 – 0917
Commands	P 0104 – 0110	Limit value configuration	P 0933 – 0966
Measuring gas pump	P 0183	Display	P 0970 – 0972
Check LS1	P 0250	Software version	P 0985 – 0990
Calibration LS1	P 0270 – 0288	Digital input 1	P 1175
Test gases	P 0330 – 0345	Digital input 2	P 1185
O ₂ measurement value configuration	P 0360 – 0362	Digital input 3	P 1195
GED heating system	P 0400 – 0403	Digital input 4	P 1205
Pressure measurement	P 0441 – 0442	Digital input 5	P 1215
Analogue output 1	P 0532 – 0534	Digital input 6	P 1225
Analogue output 2	P 0542 – 0544	Digital input 7	P 1235
Analogue output 3	P 0552 – 0554	Digital input 8	P 1245
Analogue output 4	P 0562 – 0564	Service times	P 1260 – 1261
Analogue input 1	P 0570 – 0578	LS1 linearisation	P 1280 – 1281
Analogue input 2	P 0580 – 0588	BUS interface	P 1300 – 1318
Analogue input 3	P 0590 – 0598	Dynamic monitoring LS1	P 1330 – 1331
Analogue input 4	P 0600 – 0608	PID controller	P 1350 – 1357
Analogue calculation 5	P 0610 – 0618	Configuration PID controller	P 1361 – 1367
Analogue calculation 6	P 0620 – 0628	Status PID controller	P 1381
Analogue calculation 7	P 0630 – 0638	Password/serial no.	P 1472
Analogue calculation 8	P 0640 – 0648	Parameter CRC 16	P 1490 – 1493
Analogue calculation 9	P 0650 – 0658	Probe data	P 1500 – 1563
Analogue calculation 10	P 0660 – 0668	History cal. 1-10	P 1600 – 1793
Analogue calculation 11	P 0670 – 0678	Table Ri LS1	P 1800 – 1898
Analogue calculation 12	P 0680 – 0688	Curve 1-12	P 2000 – 2565

6 Operation

6 Operation

6.1 Starting O₂ measurement

Switch on Gerät

NOTICE

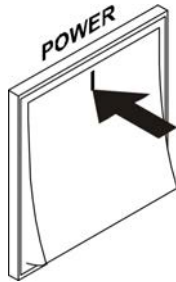

The 19" design has no switch. The voltage will be supplied by the customer.

6.2 Setting the Language for the Display and Operating Unit (optional)



Parameter 972

6.3 Interruption of Operation

Interruptions in operation
< 4 weeks

Interruptions in operation
> 4 weeks

- Continue measurement and operation of the measuring gas pump!
- Shut down measurement!
- LS1 must be removed together with the PIF!

6.4 Decommissioning

CAUTION!

Do not switch off the LT1 while the LS1 is still installed, not even when the system is shut-down. Residual gases lead to corrosion and can cause damages to system parts.

During disassembly:

- ▶ Store the devices in the open air where they are dry and protected!
 - ▶ Protect cable ends and connectors against corrosion and contamination. Corroded connectors can cause functional defects.
-

6 Operation

6.5 Practical Information

6.5.1 Damping for Jumping Display Values



If values are found to be jumping, the display can be damped. Damping is specified via:

- Parameter 360 for O₂ measurement (release level for operation)
- Parameter 441 for pressure measurement (release level for customer)

NOTICE

- ▶ A high level of damping will slow down the measurement signal.
 - ▶ Measurement values can fluctuate as a result of condensate forming in the GED.
-

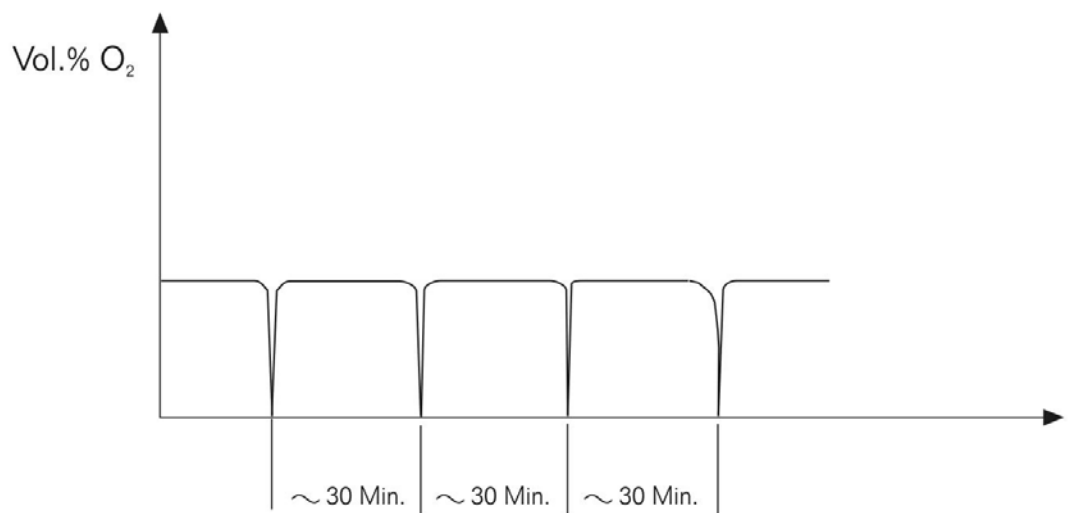

Drops of water form on the capillary tube. If a drop of water is sucked into the probe, it will evaporate. If this happens, the display will drop to 0 % by volume O₂. If conditions remain constant (measuring gas temperature), this event will occur at fairly constant intervals.

6.5.2 Measurement in Wet and Very Contaminated Exhaust Gas

NOTICE

Never draw exhaust gas through cold probe.

This can lead to a blockage of the “critical nozzle”.

Observe heating-up time!

- Observe heating up time:
 - for gas and fuel oil EL 1 hour
 - for coal and fuel oil S 2 hours
 - when incinerating refuse 2 hours
- Keep the whole length of the measuring gas sampling tube (capillary tube) above the relevant dew point for water/acid. Minimum temperature: 180 °C | 356 °F

The following should be noted:

- If the measuring gas temperature is lower, the GED must be heated up
- If the measuring gas temperature cannot be maintained along the whole length of the GED protective tube, GED protective tubes with a core made of an effective heat-conducting material (eg aluminium/copper) are to be used.

6 Operation

6.5.3 Wet/Dry Measurement Deviations, Conversion Table

NOTICE

The LT1 carries out measurements directly in the humid flue gases (wet measurement). When extractive devices are used, flue gases are removed and prepared. "Dry Measurements" are normally used here, since the humidity has been extracted from the flue gas.

As a result, O₂ measurement values vary (see diagrams below).

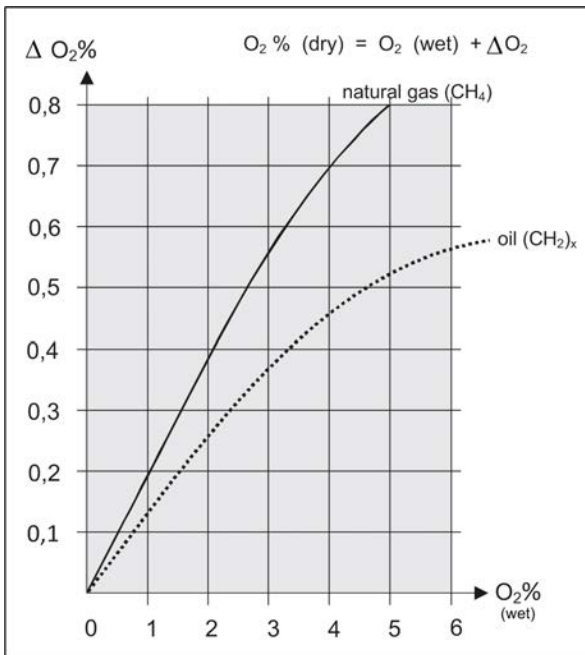

Theoretical maximum deviations between wet and dry measurement of the O₂ concentration with natural gas (CH₄) or oil (CH₂)_x as fuel

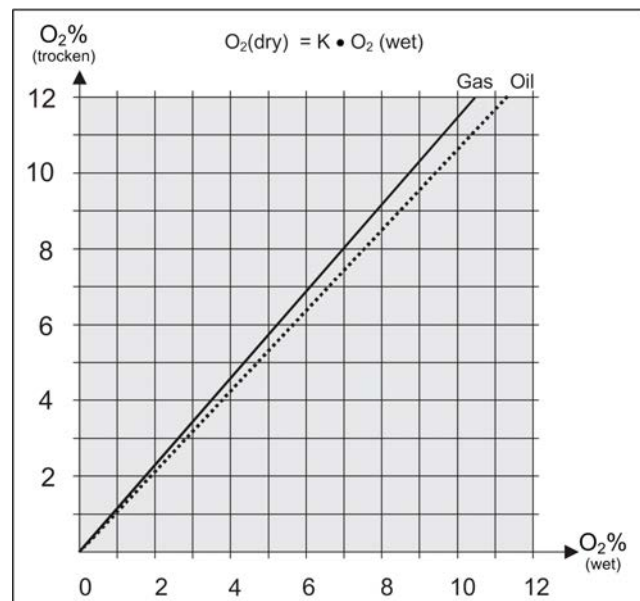

Calibration diagram and conversion table of the concentration values of wet ($O_{2(n)}$) and dry ($O_{2(tr)}$) measured oxygen

O ₂ concentration range	Constant K Gas/CH ₄	Constant K oil/(CH ₂) _x
0 - 6% O ₂	1.18	1.115
6 - 12% O ₂	1.12	1.08
0 - 12% O ₂	1.15	1.10

Alternatively, the H₂O share can be automatically calculated via a fixed factor.

6.5.4 Measurement Value Deviations due to Changes in Pressure

The measurement value is controlled by pressure. The error influence is 1.3 % of the measurement value for each 10 mbar by which the pressure changes.

Example:

Meas. value	=	21 Vol. %
Error	=	0.3 Vol. % by volume with an increase in pressure of 10 mbar

The measurement value can be corrected by means of pressure compensation. Pressure compensation is available as an option. It is included as standard with the automatic calibration unit.

7 Maintenance

7 Maintenance

7.1 Maintenance Schedule

7.1.1 Check Measurement

Checking of the measurement is carried out according to the application in each case:

- weekly
- monthly
- quarterly

7.1.2 Replace Wear Parts

	Average service life
Lambda Probe LS1	2 - 4 years
measuring gas pump	2 - 3 years
Diaphragm (pump)	1 - 2 years
Protective pump filter (measured gas side)	3 - 6 months (depending on fuel)
Sintered metal pre-filter in extraction unit	depending on fuel in the case of biofuel, coal and heavy oil, change annually

7.1.3 Maintenance Tasks

Maintenance is governed by the particular application and by the degree of contamination of the waste gases being measured.

The following preventive maintenance is recommended for emission measurement on a coal-fired furnace (clean gas side):

Maintenance I (monthly)

Empty condensate trap.

NOTICE

The condensate must be collected and disposed of.

Inspect filter on the measured gas side, replace if necessary.

Check the probe (calibration) as described in *7.2.5 Checking and Calibrating the Probe*

Maintenance II (half-yearly)

Maintenance I

In addition, check pump:

Negative pressure:	more or equal to 0.6 bar less or equal to 0.4 bar absolute
Pressure switch operating point	0.45 ... 0.58 bar negative pressure

Maintenance III (yearly)

Maintenance I and II

In addition

Clean pump head; inspect diaphragms, valves and seals and replace if necessary.

NOTICE

With biofuel, heavy fuel oil and coal, change the complete GED is better than one sintered metal filter!

As required

- Replace gas extraction device (GED) if blocked
- Clean extraction attachment at the tip of the GED. Replace or renew the filter.
- Clean or replace the filter attachment if the warning “sintered metal pre-filter dirty” is indicated, or on the basis of empirical values
- Replace moulded insulation part in the PIF (inside) if broken
- Replace the “critical nozzle” if there is an “insufficient flow” warning, $I_{\text{probe}} < 260 \text{ mA}$

NOTICE

It is recommended to carry out the above maintenance tasks during scheduled installation lay-up periods as part of the maintenance schedule.

7 Maintenance

7.1.4 Draining off the Condensate

1. Switch off pump

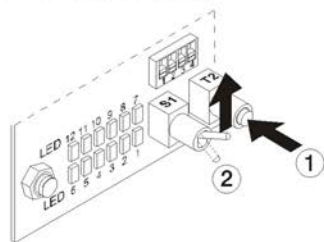

OR



 Parameter 100

2.  3.

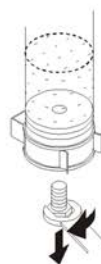
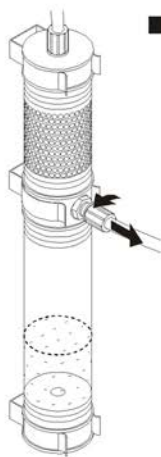

4. 

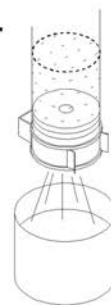

Drain off condensate

5.  6.

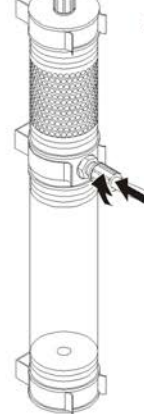

7. Switch on pump

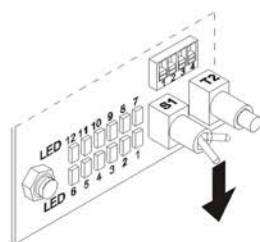

OR



 Parameter 100

8. Determine pump operating time

→ See chapter 7.1.10 *Determining the Pump Operating Time.*

7 Maintenance

7.1.5 Replacing the Pump Protection Filter

1. Switch off pump

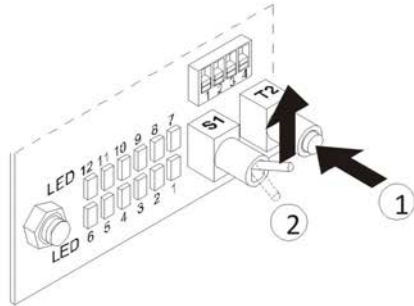

OR



Parameter 100

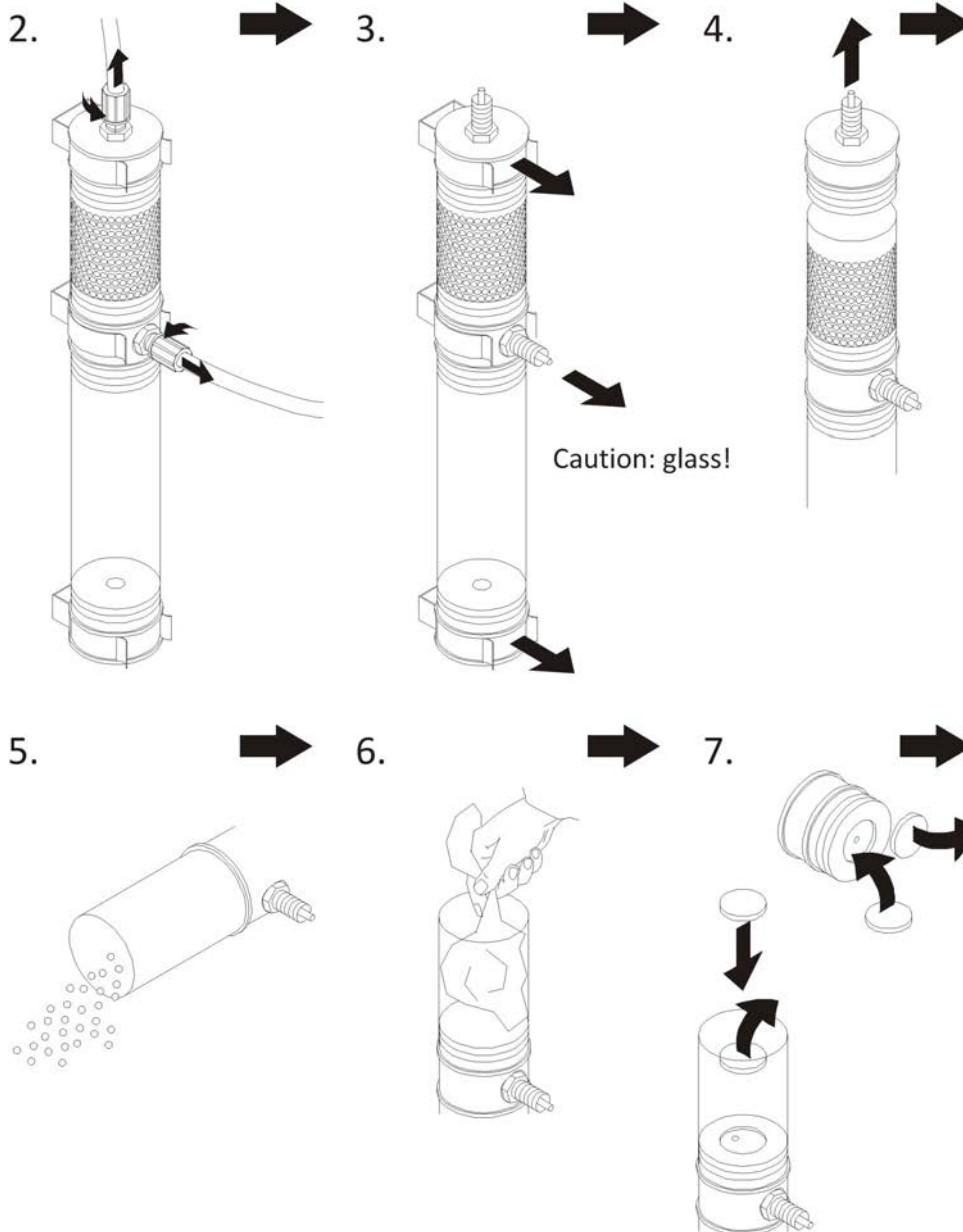

7 Maintenance

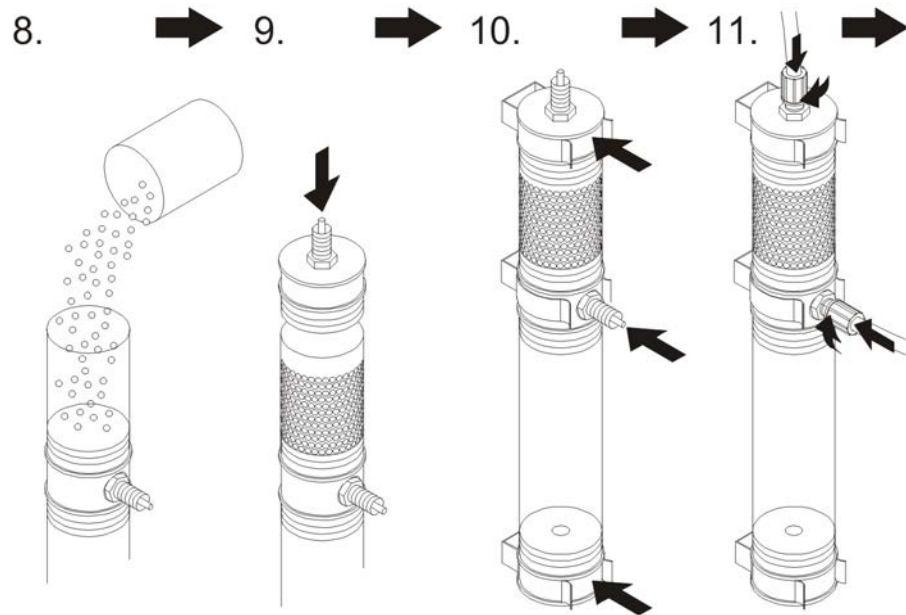

12. Switch on pump

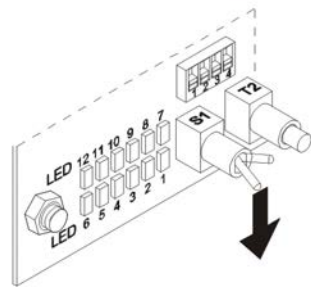

OR



Parameter 100

13. Determine pump operating time

→ See chapter 7.1.10 *Determining the Pump Operating Time.*

7 Maintenance

7.1.6 Removing the Measuring Gas Pump

1. Switch off pump

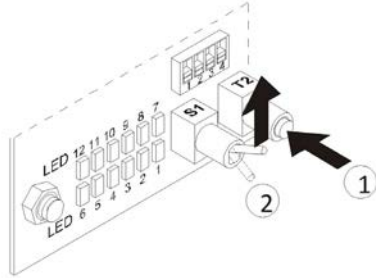

OR



Parameter 100

2.

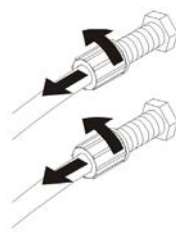

3.

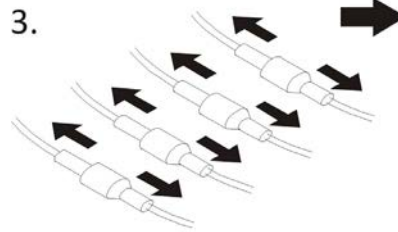

4. Before 1998

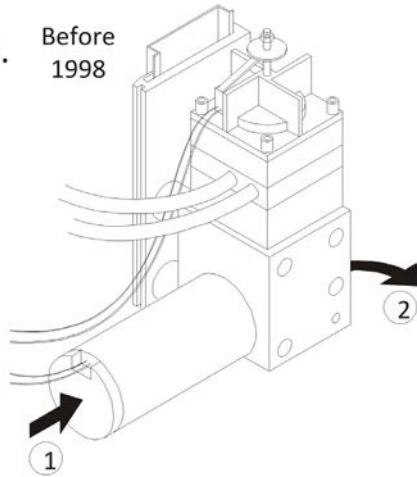

Since 1998

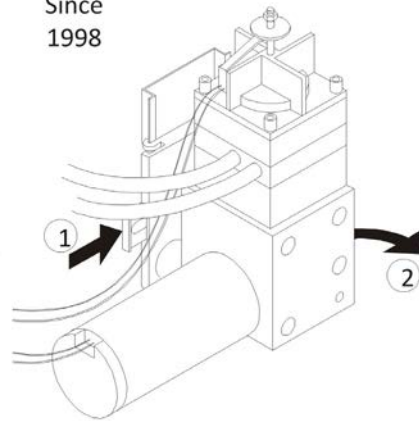

7.1.7 Installing the Measuring Gas Pump

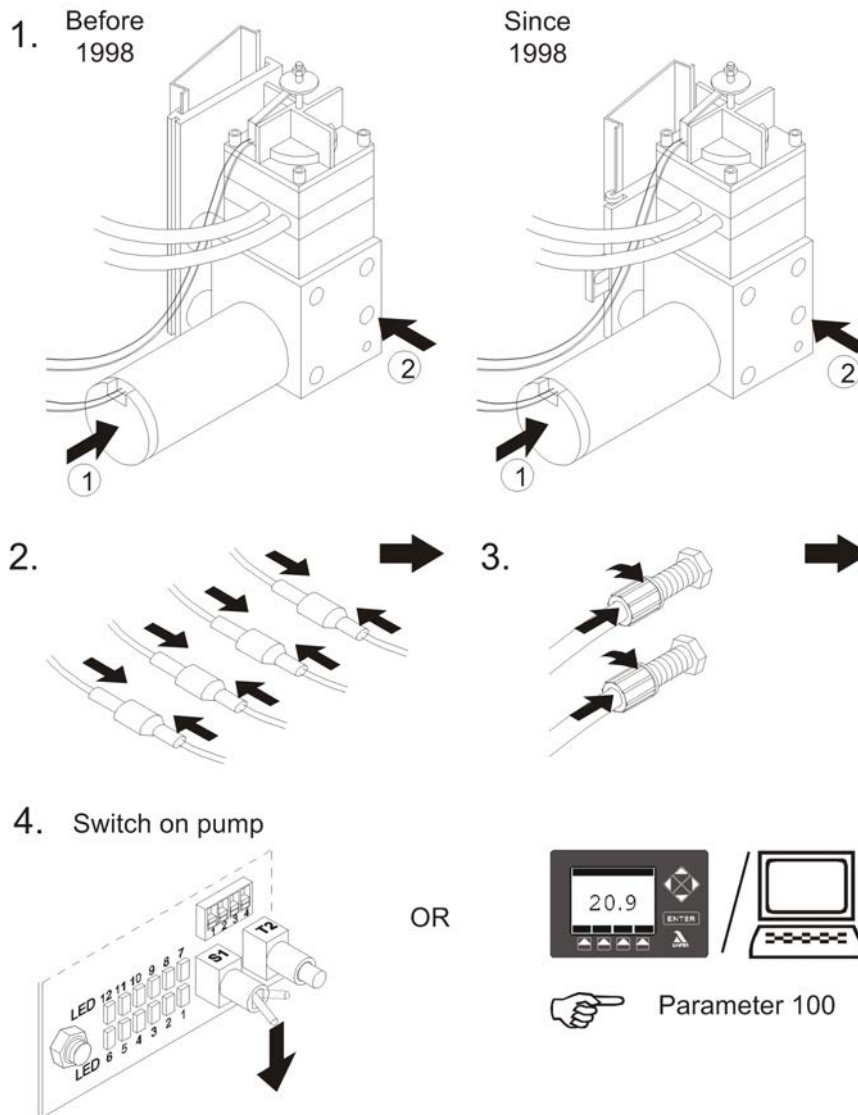

→ See chapter 7.1.10 *Determining the Pump Operating Time*.

NOTICE

The operating time and the number of cycles for the measuring gas pump can be integrated via parameters 78 and 80.



Recommendation:

After changing the pump, reset the operating time and the number of cycles via parameter 105.

7 Maintenance

7.1.8 Dismantling the Pump Head

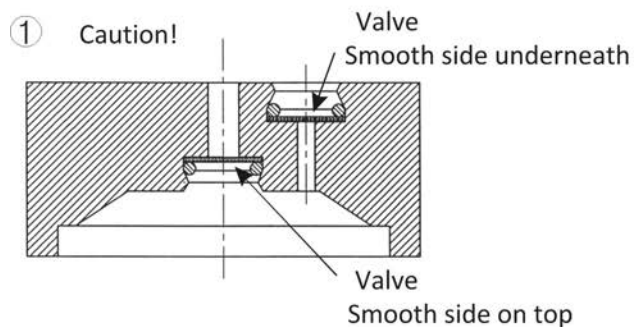
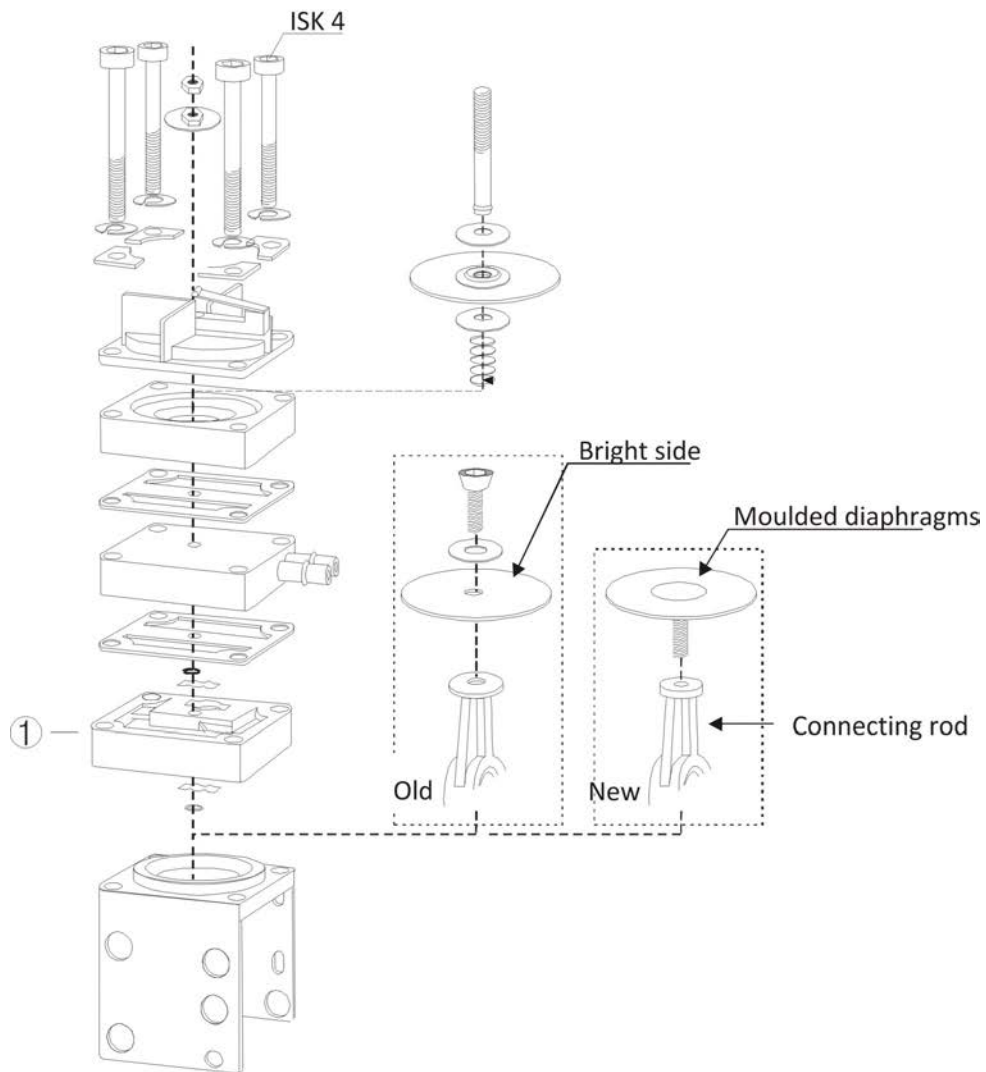

⚠ CAUTION!

None of the valves can be changed in the pumps designed for use with aggressive measuring gases. The whole pump chamber will have to be changed.

When converting to moulded diaphragms, the connecting rod must also be replaced.

7 Maintenance

7.1.9 Cleaning the Pump Head

- Do not use hard objects to clean the valve blocks.
- Do not use solvent.
- Replace hardened rubber parts.

7.1.10 Determining the Pump Operating Time

It is necessary to determine the pump operating time after:

- replacing the measuring gas pump
- servicing the measuring gas pump (cleaning, changing diaphragms/valves etc.)
- replacing the pump protection filter
- rectifying leaks in the measuring gas hose

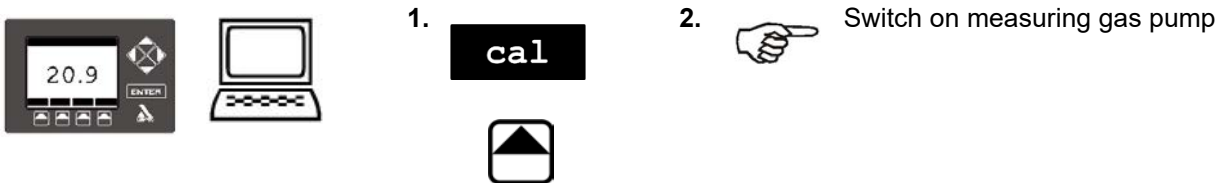
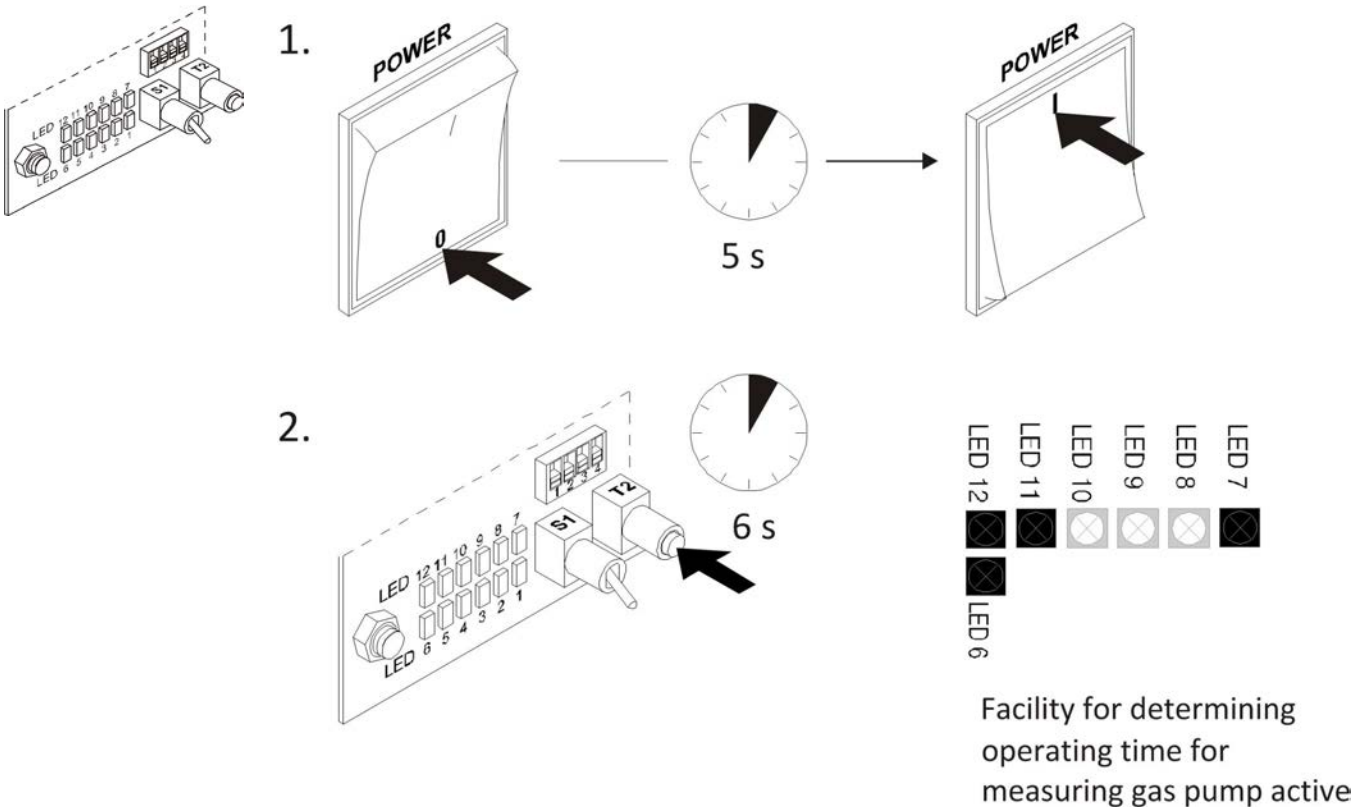

7.2 Replacing the Probe

With automatic calibrating device:

- 1 Remove defective probe from PIF, see chapter 7.2 *Replacing the Probe*.
- 2 Install GED in new probe, see chapter 7.2.4 *Installing the GED*.
- 3 Install new probe in PIF, see chapter 7.2.2 *Installing the Probe*.
- 4 Reset probe heating controller to basic value, see chapter 7.2.6 *Resetting the Probe Heating Controller to the Basic Value*.
- 5 Fill out probe record card, see chapter 7.2.7 *Completion of Probe Record Card*.

Without automatic calibrating device:

- 1 Remove PIF with defective probe
- 2 Remove defective probe from PIF.
- 3 Install GED in new probe, see chapter 7.2.4 *Installing the GED*
- 4 Install new probe in PIF
- 5 Reset probe heating controller to basic value, see chapter 7.2.6 *Resetting the Probe Heating Controller to the Basic Value*
- 6 Wait during heating-up time:
 - for gas and fuel oil EL: 1 hour
 - for coal and fuel oil S: 2 hours
 - when incinerating refuse: 3 hours

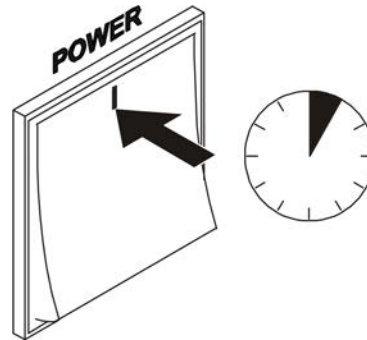

- 7 Initiate calibration, see chapter 7.2.5 *Checking and Calibrating the Probe*. Repeat calibration after 24 hours.
- 8 Install PIF with new probe
- 9 Fill out probe record card, see chapter 7.2.7 *Completion of Probe Record Card*.

7 Maintenance

7.2.1 Removing the Probe

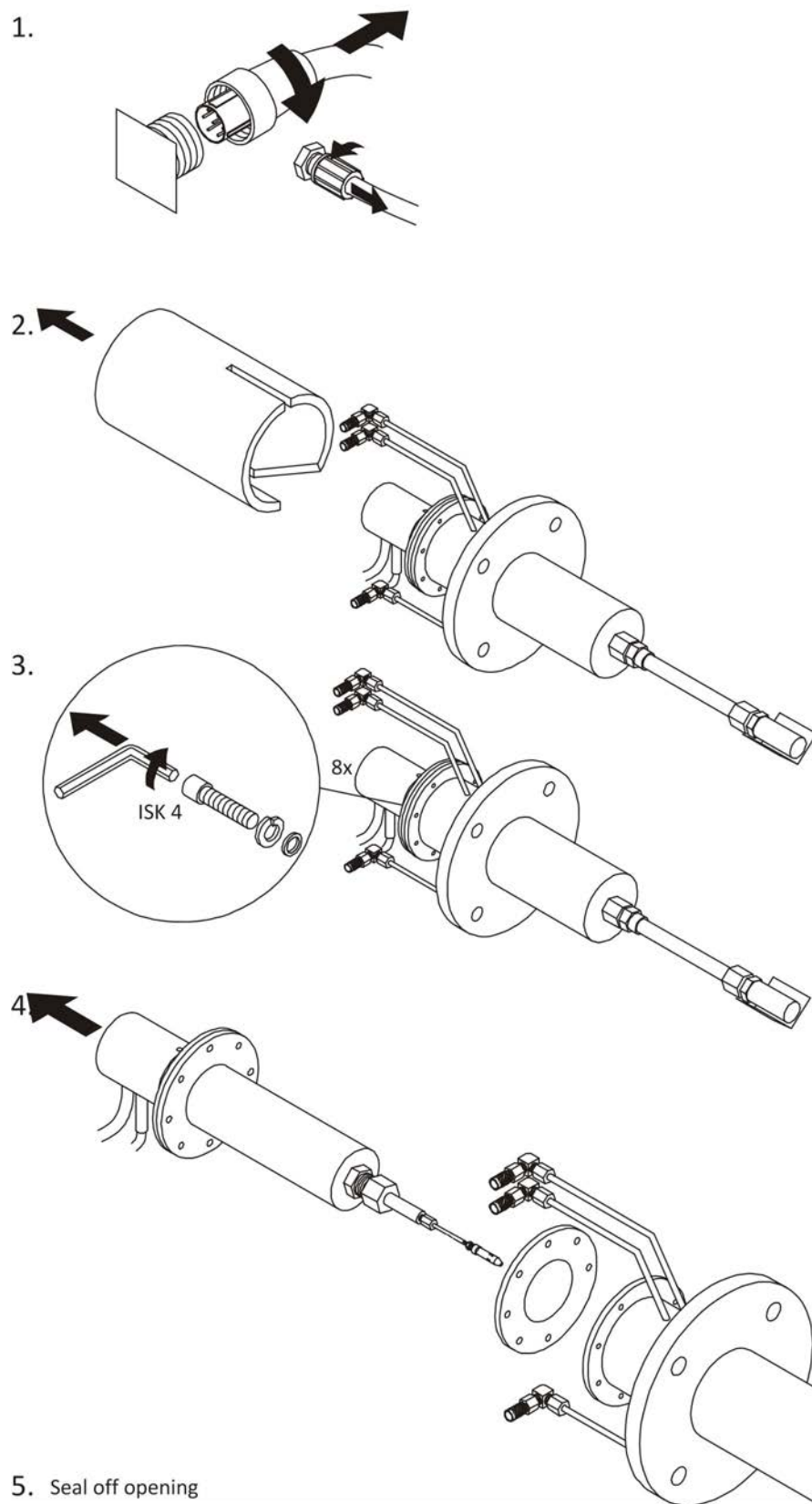

7 Maintenance

7.2.2 Installing the Probe

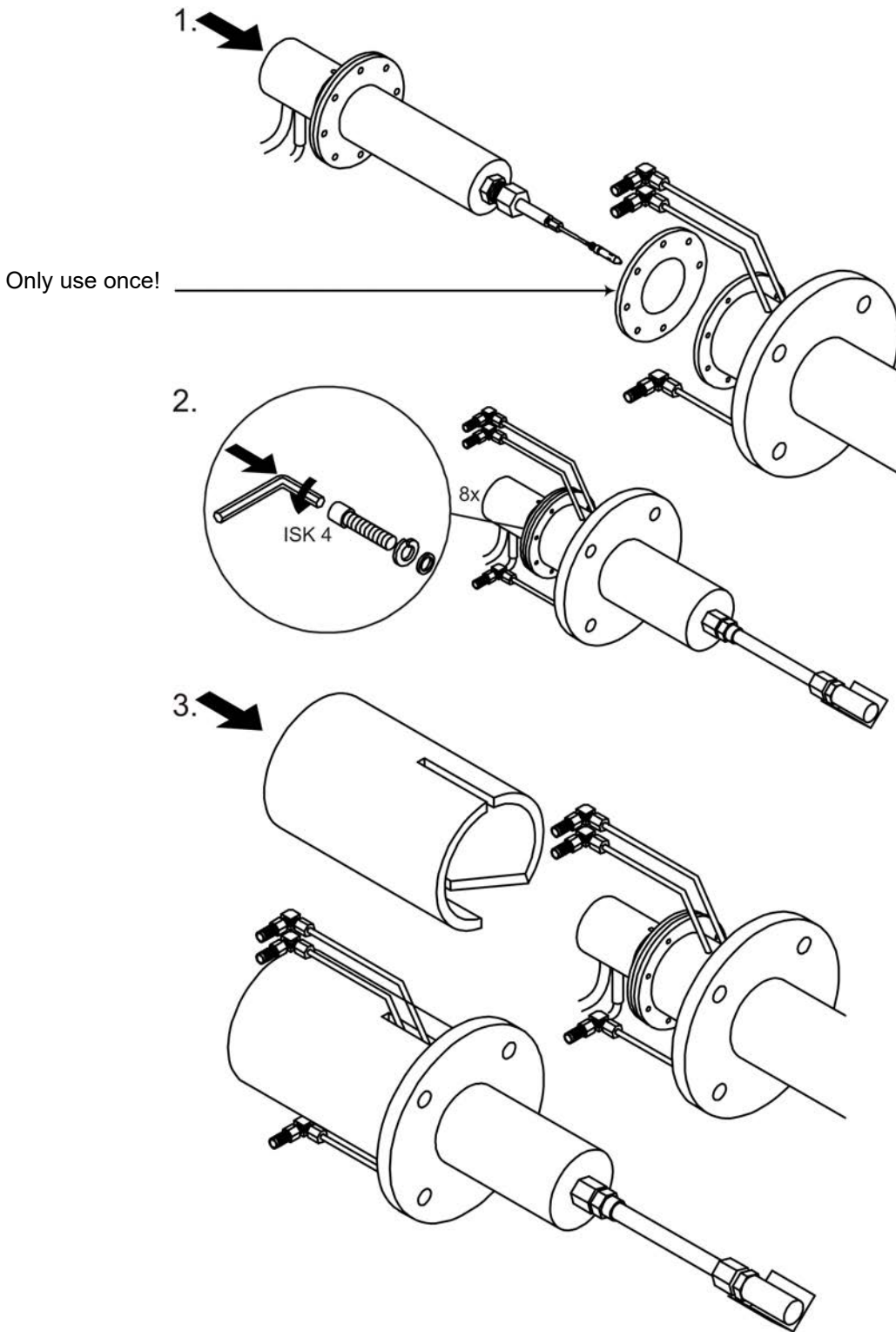

7 Maintenance

7.2.3 Removing the GED

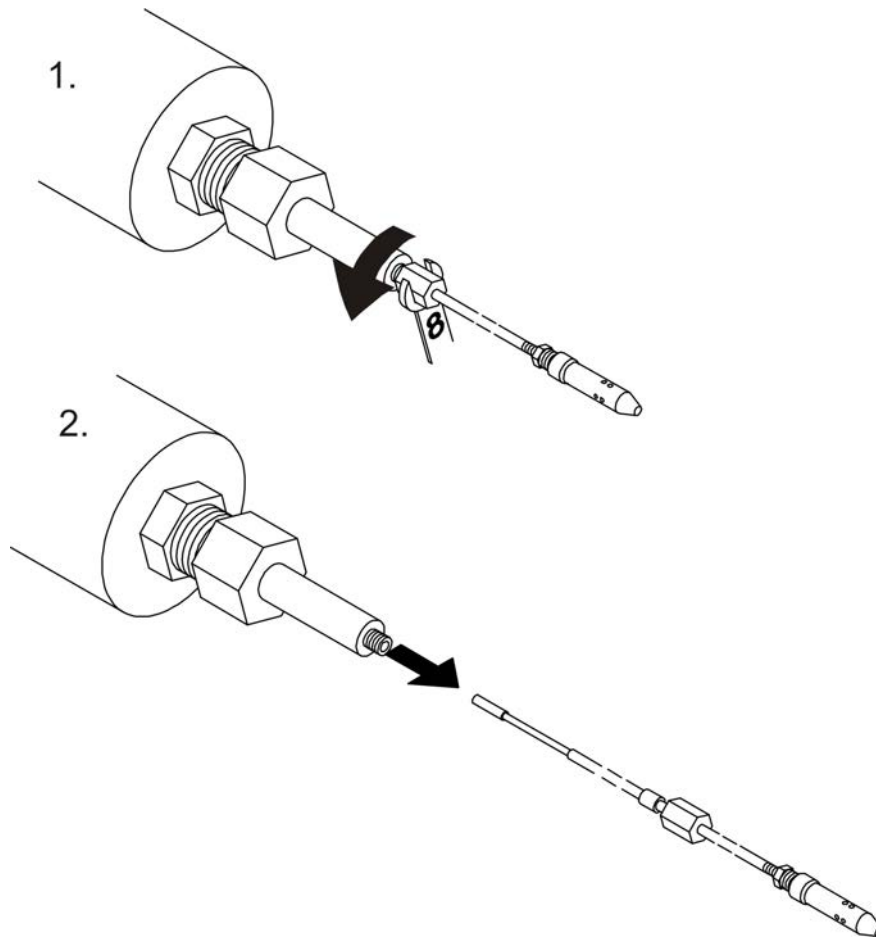

7 Maintenance

7.2.4 Installing the GED

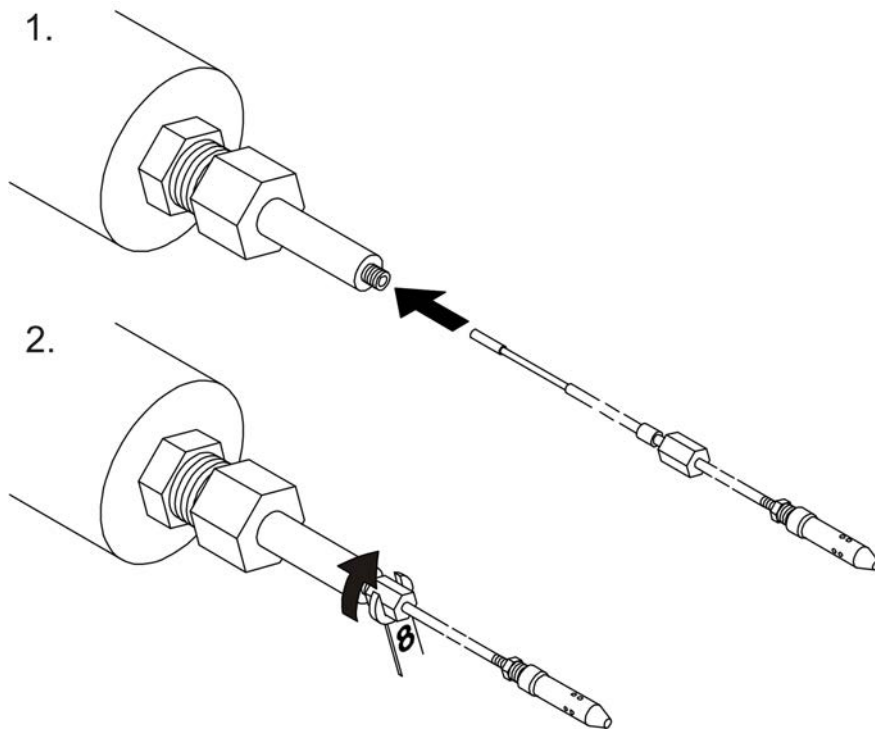

7 Maintenance

7.2.5 Checking and Calibrating the Probe

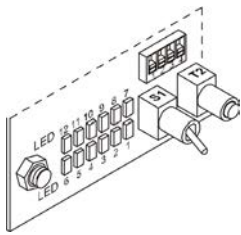

1. Without automatic calibration unit

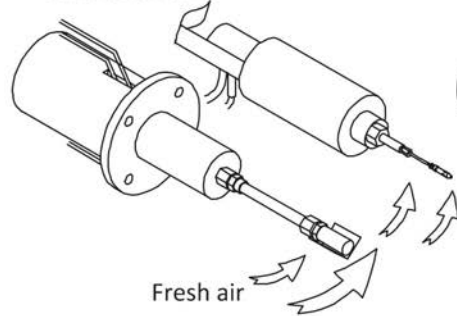

With automatic calibration unit

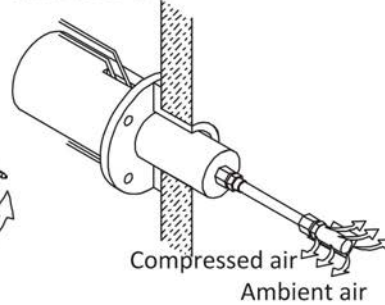

2.

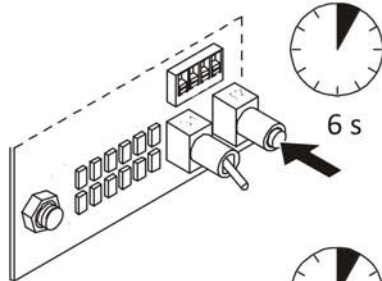

6 s



Calibration is active



1 - 5 Minuten



Operating mode: measurement

Vorzeitiger Abbruch der Kalibrierung:

1.

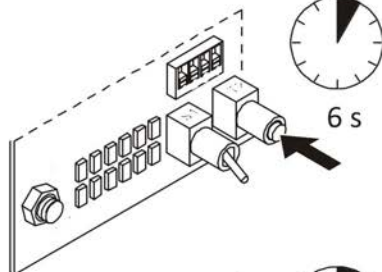

6 s



Fast → Slow

Calibration is active

2.

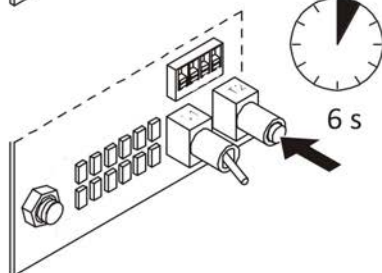

6 s



Operating mode: measurement



cal



7 Maintenance

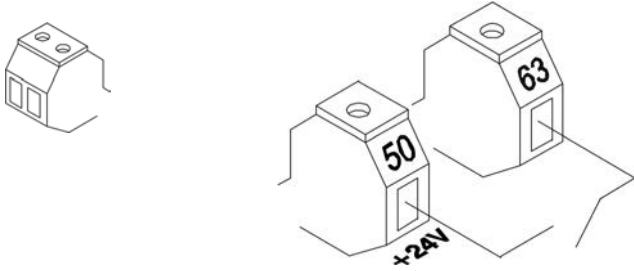

Digital input
(factory setting: input 2)

7.2.6 Resetting the Probe Heating Controller to the Basic Value

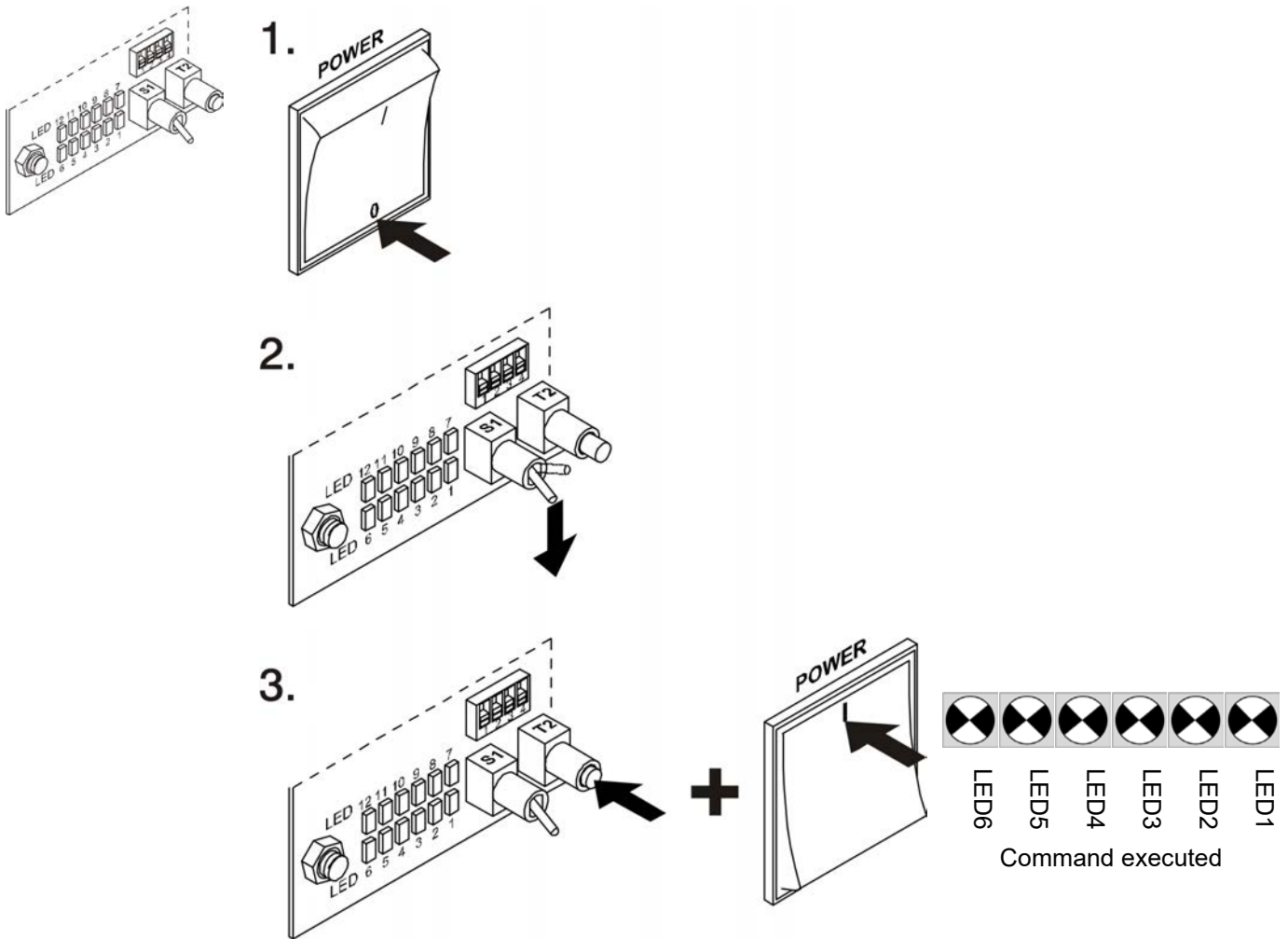

Parameter 104 (change probe)

7 Maintenance

7.2.7 Completion of Probe Record Card

Measure	
O2 output	20.9 Vol.%
Abs. pressure	1003 mbar
Current	468 mA
O2-Int. cmp.	20.9 Vol.%
meas	cal
par	diag

Probe Record Card, back
Checks

Datum Date	O ₂ -Wert O ₂ value bei Umgebungsluft in ambient air	Sondenstrom Probe current	Heizleistung LS1/heat output (Parameter 54)	Abgeglichen Recalibrated		Bemerkungen Remarks
				ja yes	nein no	
14.1.98	20,5	407	75W	X		20,9

7.2.8 Activating Service Warnings



Parameter 1260, 1261

8 Faults/Warnings

8 Faults/Warnings



Messages appear in clear text

8.1 Display via Processor Board

Call up faults and warnings

Display the next fault/warning:

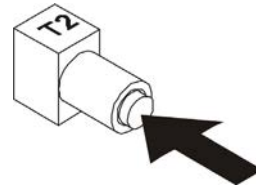

8.2 Warnings

Legend: LED



is off



is flash-
ing



is illuminated

7	8	9	10	11	12	Warnings
						No warning
						Defect in probe heating controller
						Sintered metal preliminary filter dirty
						Flow rate too low, probe < 260 mA ¹
						O ₂ sensor worn out; replace
						Leak in measuring gas hose
						GED heating system defective
						Preliminary filter heating system defective
						Quantity of calibrating gas too low, increase flow rate
						Pressure outside the permissible range
						Temperature outside the permissible range
						Do not draw exhaust gas through cold probe

8 Faults/Warnings



































































7	8	9	10	11	12	Warnings
						Temperature measurement LS1 incorrect
						Not assigned
						Not assigned
						Probe current restriction LS1 active
						Mains voltage too high/too low
						Determination of operating time for measuring gas pump active
						Probe current not constant during calibration
						Analogue input 1: input value too high/low
						Analogue input 2: input value too high/low
						Analogue input 3: input value too high/low
						Analogue input 4: input value too high/low
						Configuration error analogue outputs
						Service warning 1
						Service warning 2
						Probe dynamics LS1 missing
						Dynamic test initiated

1 Check parameter 51: Probe current from last calibration.

8 Faults/Warnings

8.3 Faults

Legend: LED  is off  is flashing  is illuminated

7	8	9	10	11	12	Fault
						No fault
						Probe defective
						Flow rate too low probe < 200 mA ¹
						Partial vacuum (measuring gas pump)
						Probe heating system defective
						Broken wire in probe or CO peak
						Calibrating/measuring gas pump (excessive drawing of current)
						Probe current not constant (test gas)
						Test gas/to purge
						Probe dynamics LS1 missing
						Sintered metal preliminary filter dirty

1 Parameter 51: Probe current from last calibration.

8.3.1 Internal Electronics Faults

Legend: LED  is off  flashes  lights up

7	8	9	10	11	12	Fault
						electronics fault (rapid flashing)

If an internal fault occurs, you must consult the manufacturer. For the address of the manufacturer, see "General Notes".

8.3.2 Resetting Faults/Warnings

8 Faults/Warnings

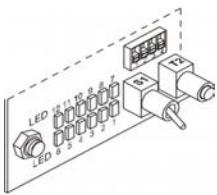

> 3 s/fault



diag

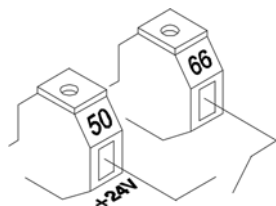

Digital input
(factory setting: input 5)

8 Faults/Warnings

8.3.3 Cause of Fault

Fault/warning message information	Possible cause	Troubleshooting
Probe defective Internal resistance of the zirconium dioxide measuring cell too high	Measuring cell worn out or broken	Send probe to be repaired
Flow rate too low Fault: Probe current at air less than 200 mA Warning: Probe current at air less 260 mA	GED blocked	Replace GED
	Measuring gas hose blocked or it has a kink in it	Replace hose
	Nozzle blocked	Replace nozzle
Partial vacuum measuring gas pump Unauthorised release of pump pressure switch	Fuse F 203	Check fuse
	Pump circuit interrupted	Check male cable connector
	DC motor (12 V) defective	Replace measuring gas pump
	Leak in measuring gas hose, in the couplings or in the pump head	Check hose and connections, check pump for leaks
	Measuring gas return path blocked	Clean measuring gas return pipe at PIF
	Diaphragms broken or pump head dirty	Clean pump head and change gas-kets / diaphragms
	Pump protection filter / condensate tank leaking	Check and replace if necessary
	Pump pressure switch (microswitch on pump head) defective or operating point misadjusted	Replace measuring gas pump
Probe heating system defective	LS1 Lambda Probe has been disconnected	Connect probe
	Fuse F 206 and F 207	Check fuses
	Probe heater defective	Check probe heater If defective, replace probe
	Fault in electronics	Change LT1
Probe wire breakage	CO peak > 10.000 ppm	
	Probe not connected	Connect probe
	Fuses F 208 defective	Check fuses
	Broken wire in probe feeder or probe connector	Check probe heater If defective, replace probe
	Probe defective	Send probe to be repaired
Excessive drawing of current in pump (measuring/calibrating gas pump)	Bearing damage to measuring gas pump	Replace measuring gas pump
	Bearing damage to calibrating gas pump	Replace calibrating gas pump

8 Faults/Warnings

Fault/warning message information	Possible cause	Troubleshooting
	Calibrating gas feed, preliminary pressure too high	Reduce preliminary pressure at calibrating gas inlet
	Restriction flow too low and discharge valve blocked	Replace calibrating device
Probe current not constant	Very high pressure fluctuations at the measurement point or defective probe	Send probe to be repaired
Fault with test gas/to purge Only in conjunction with test gas connection option/Purge the pre-filter	Test gas bottle is empty, pre-filer has closed or become blocked (purge)	Check, deactivate test gas connection
	Other cause such as "Probe current not constant"	
No LS1 probe dynamics	Gas path blocked: <ul style="list-style-type: none"> • GED • Critical nozzle • Hose connection • Sintered metal preliminary filter • Measuring gas hose pinched 	Initiate check/calibration
	Parameter set incorrectly	
Internal faults in the electronics	Defect on processor board	Replace processor board
Heating control system defective Switch-over to a fixed voltage of 29 VAC as an emergency power supply	Fuse F206	Check fuse, if necessary send LT1 to be repaired
Preliminary filter dirty Pressure monitoring for permeability of the preliminary filter: > 50 mbar	Preliminary filter is clogged up	Check quantity of calibrating gas, close restrictor a little if necessary Remove PIF and clean filter, replace if necessary
O2 sensor too old, replace Measurement can be continued with reservations		Send probe to be repaired
Measuring gas hose leaking	Measuring gas hose	Check for leaks, determine pump operating time
	Couplings	
	Condensate tanks	
	Measuring gas pump	
GED heating system defective	GED heating system defective	Replace GED heating system
	Contact resistance	Check wiring
	GED heating system electronics defective	Replace electronics
Preliminary filter heating system defective	See: GED heating system defective CAUTION: Heater must fire to filter properly. Heat transfer!	Replace preliminary filter heating system

8 Faults/Warnings

Fault/warning message information	Possible cause	Troubleshooting
Quantity of calibrating gas too low; increase flow rate Only relevant in connection with the option "Automatic calibrating device"	Hoses have a kink in them at the PIF	Check/replace hoses
	Quantity of calibrating gas too low	Increase calibration quantity
	Preliminary filter missing (truncated)	Change preliminary filter
	Calibrating gas feed blocked	Check calibrating gas feed, clean Replace filter
Absolute pressure too high or too low	Measuring gas pressure during operation or calibration: < 100 mbar > 1100 mbar	Is the absolute pressure displayed plausible? If not: replace pressure sensor
Temperature probe too high/low, LS1 temperature def. Only relevant in connection with the option "Automatic calibrating device"	Wiring	Check
	PT100 sensor defective	Replace PT100 sensor
Do not draw exhaust gas through cold probe	The cold-start delay has been deliberately aborted	No activity required
LS1 probe current restriction active Probe current greater than 1000 mA	probe (quartz glass measuring chamber broken)	Send probe to be repaired
	Electrical connection of the probe	Check connection
	Electronics (probe voltage control system defective)	Send LT1 to be repaired
Mains voltage too high or too low	With mains voltage fluctuations < $\pm 15\%$: defect in the mains voltage compensation	Send LT1 to be repaired
Determination of operating time for measuring gas pump active	Cyclic function - used to check the measuring gas pump	No activity required
Probe current not constant during calibration The probe current shows strong fluctuations during calibration	Quantity of calibrating gas too low	Increase quantity of calibrating gas
	Sintered metal preliminary filter broken	Replace sintered metal preliminary filter
	Leak in probe fitting (PIF), Lambda probe etc.	Check gaskets and couplings
	Quartz glass measuring chamber in the Lambda probe broken	check Lambda probe for leaks
	Strong fluctuations in pressure during calibration	
Analogue input 1/2/3/4 Input value too high/low The input value at the relevant analogue input is outside the permissible range	Fault wiring (polarity reversed?)	Check wiring
	Source (connected device)	Check source (customer)
	Input card defective	Replace input card
Configuration error CAUTION! Incorrect analogue values can be produced as a result of a configuration error	A non-assembled analogue output has been activated	Check assembly of the analogue output modules Compare parameters 530/540/550 and 560 for analogue output modules 1 to 4

8 Faults/Warnings

Fault/warning message information	Possible cause	Troubleshooting
Service warning 1/ Service warning 2 The service warnings serve to indicate regular services. The service warnings are deactivated at the factory.		
Dynamic test initiated The dynamic test is deactivated at the factory	See probe dynamics	No activity required

8.3.4 Information on the Faults

- 1 If the measurement system works properly again after the fault has been acknowledged and the defect continues to occur at sporadic intervals, the cause of the fault is the microswitch (contact resistance in the contact area). If this is the case, the measuring gas pump is to be replaced.
- 2 With CO peaks of > 10,000 ppm, the ZrO₂ measuring element will produce a voltage (emf) which may cause the open-circuit monitoring system to respond.
- 3 Installation instructions and connection diagrams are supplied with the spares.

8 Faults/Warnings

8.4 Troubleshooting

8.4.1 Replace the Processor Board

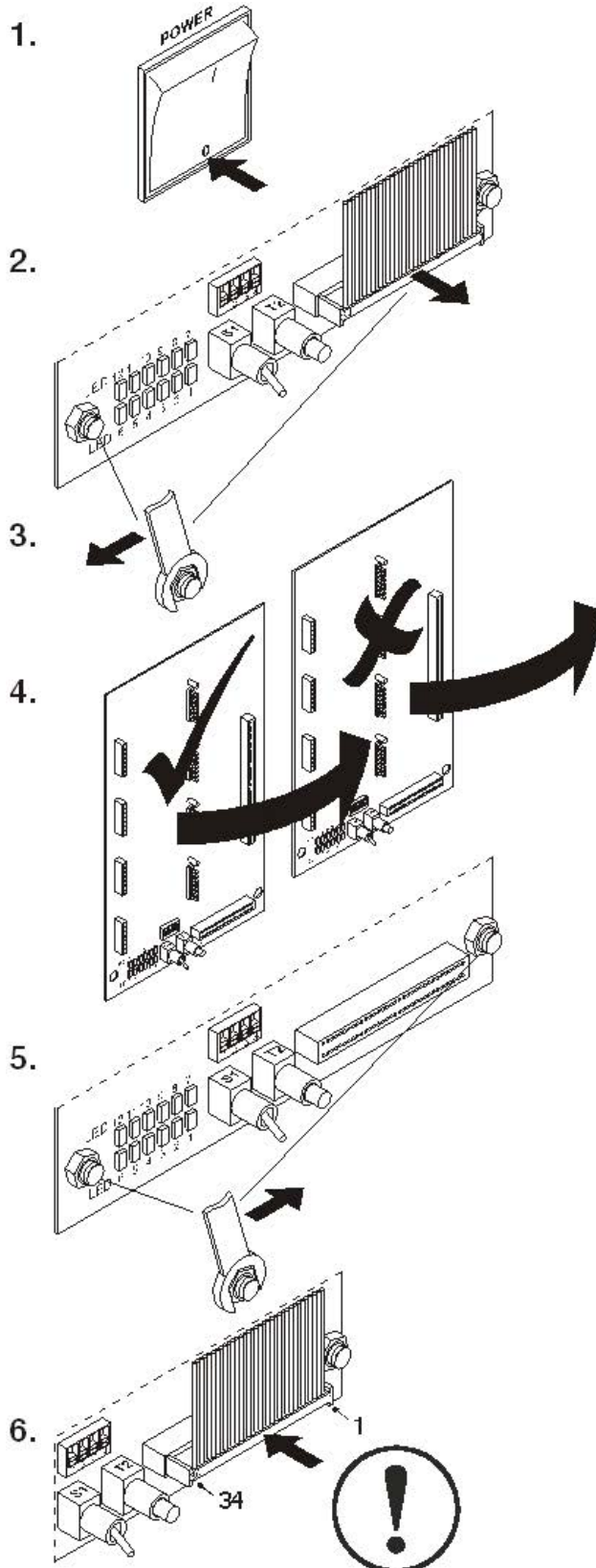

8 Faults/Warnings

8.4.2 Checking the Tightness of Seal of the Lambda Probe LS1

1. Remove the probe (see chapter 7.2 *Replacing the Probe*)
2. Connect the probe

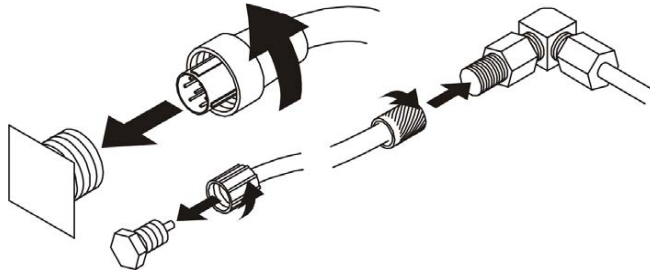

3. Select operating mode
4. Remove GED (see chapter 7.2.3 *Removing the GED*)
5. Connect the pressure gauge

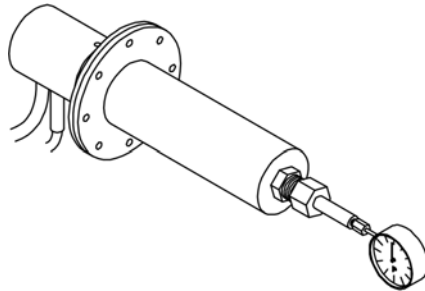

Partial vacuum gauge
Order no.: type 652R0230

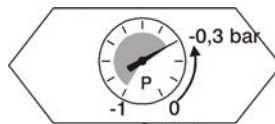

Yes



Probe is leakproof

Nein

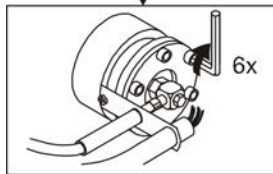
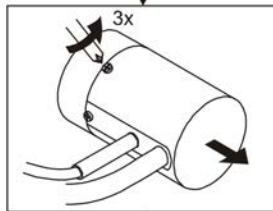

Yes



Probe is leakproof

No



Send probe to be repaired

8 Faults/Warnings

8.4.3 Check the Measuring Gas Hose for Leaks

1. Check:

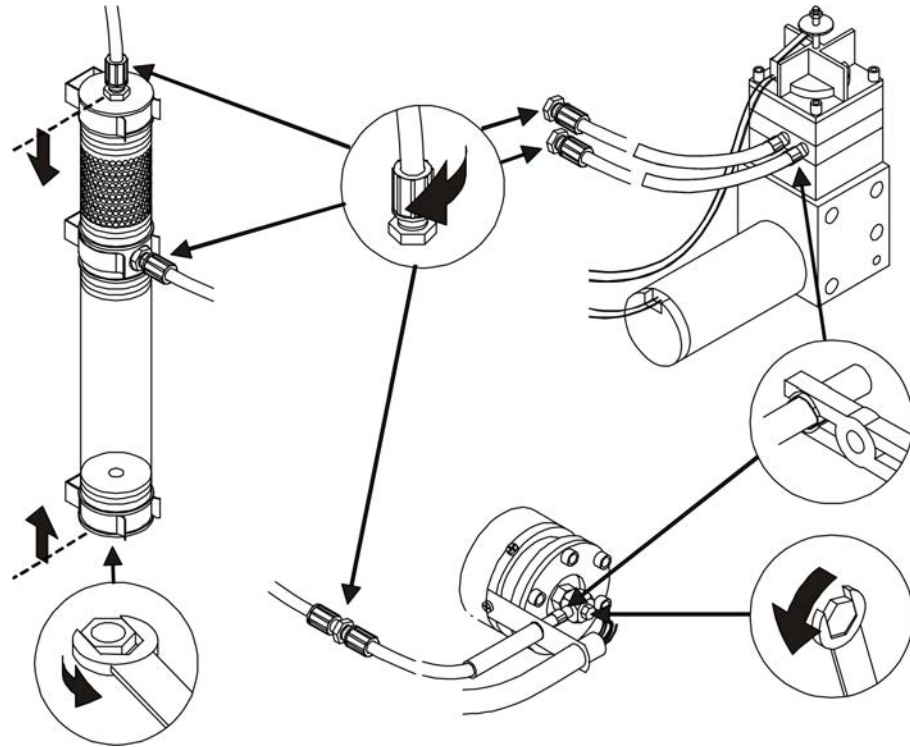

2. Determine pump operating time (see chapter 7.1.10 *Determining the Pump Operating Time*)

8.4.4 Change the Quantity of Calibrating Gas

Measure	
O2-output	20.9 Vol. %
Abs. pressure	1003 mbar
Current	468 mA
O2-Int. Cmp.	20.9 Vol. %

meas cal par diag

Recommended increase in pressure:
1 ... 5 mbar

8 Faults/Warnings

8.4.5 Change PT100

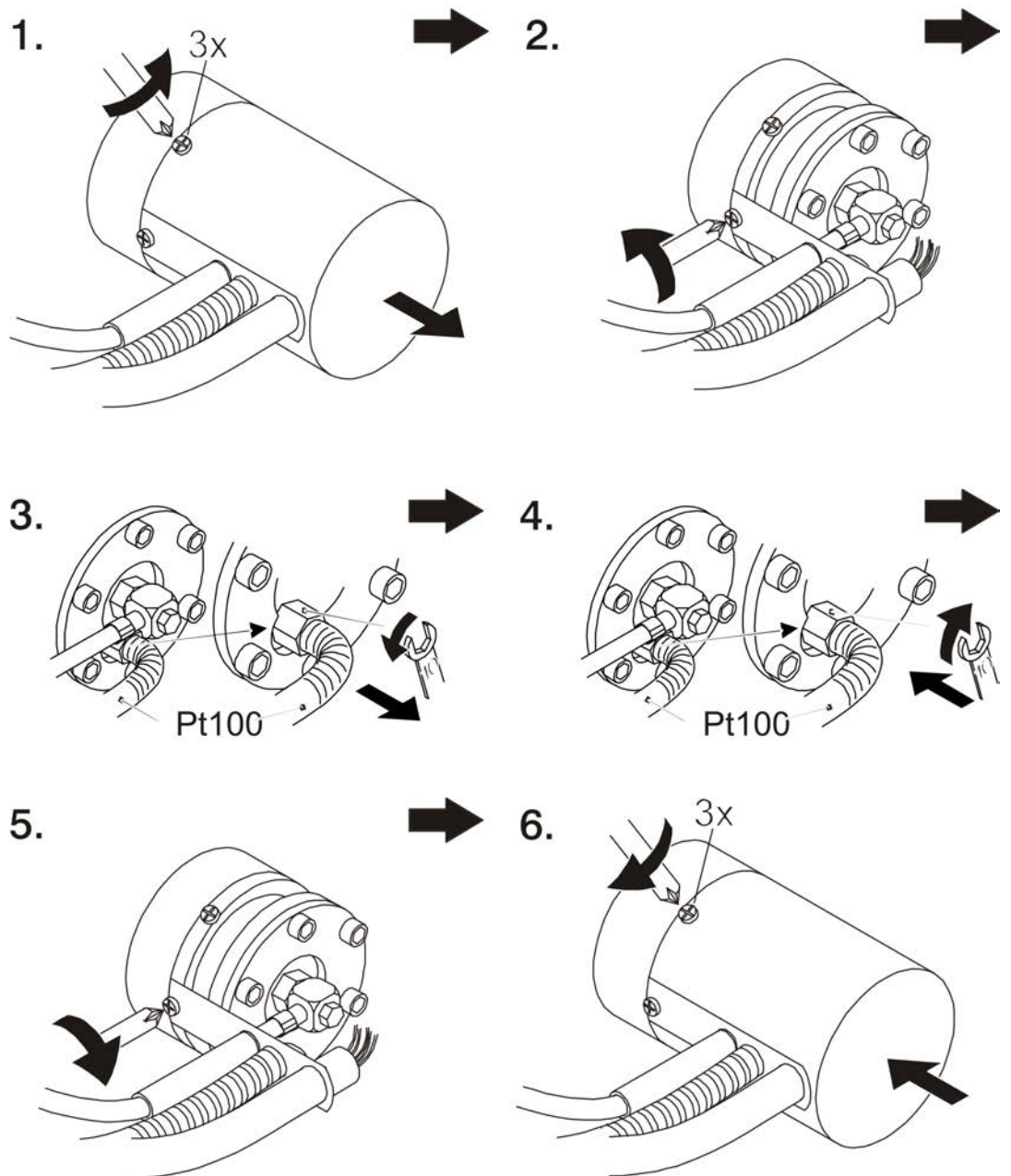

8 Faults/Warnings

8.4.6 Replacing the "Critical Nozzle"

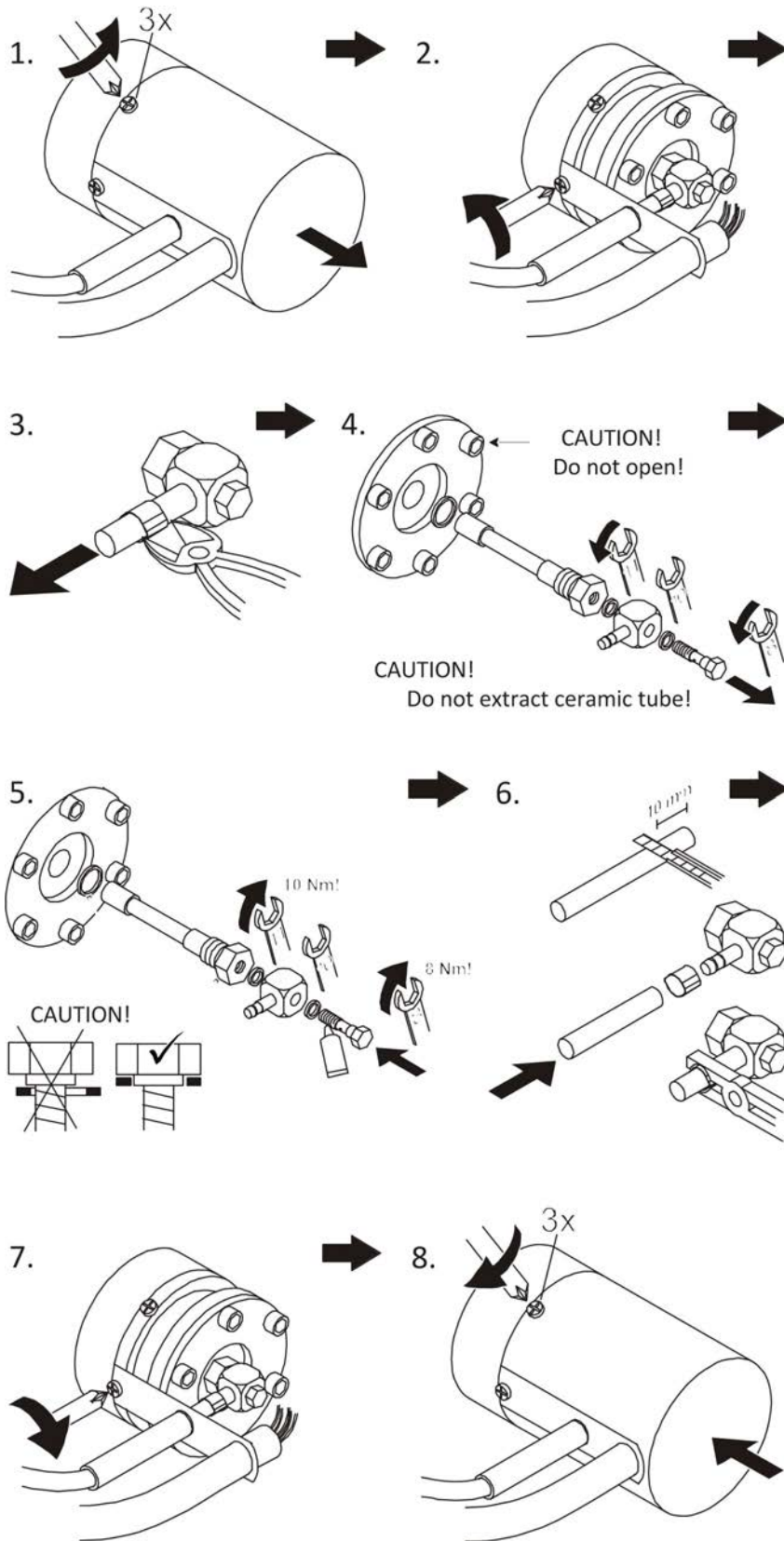

8.4.7 Cleaning the Sampling Attachment with the Sintered Metal Filter

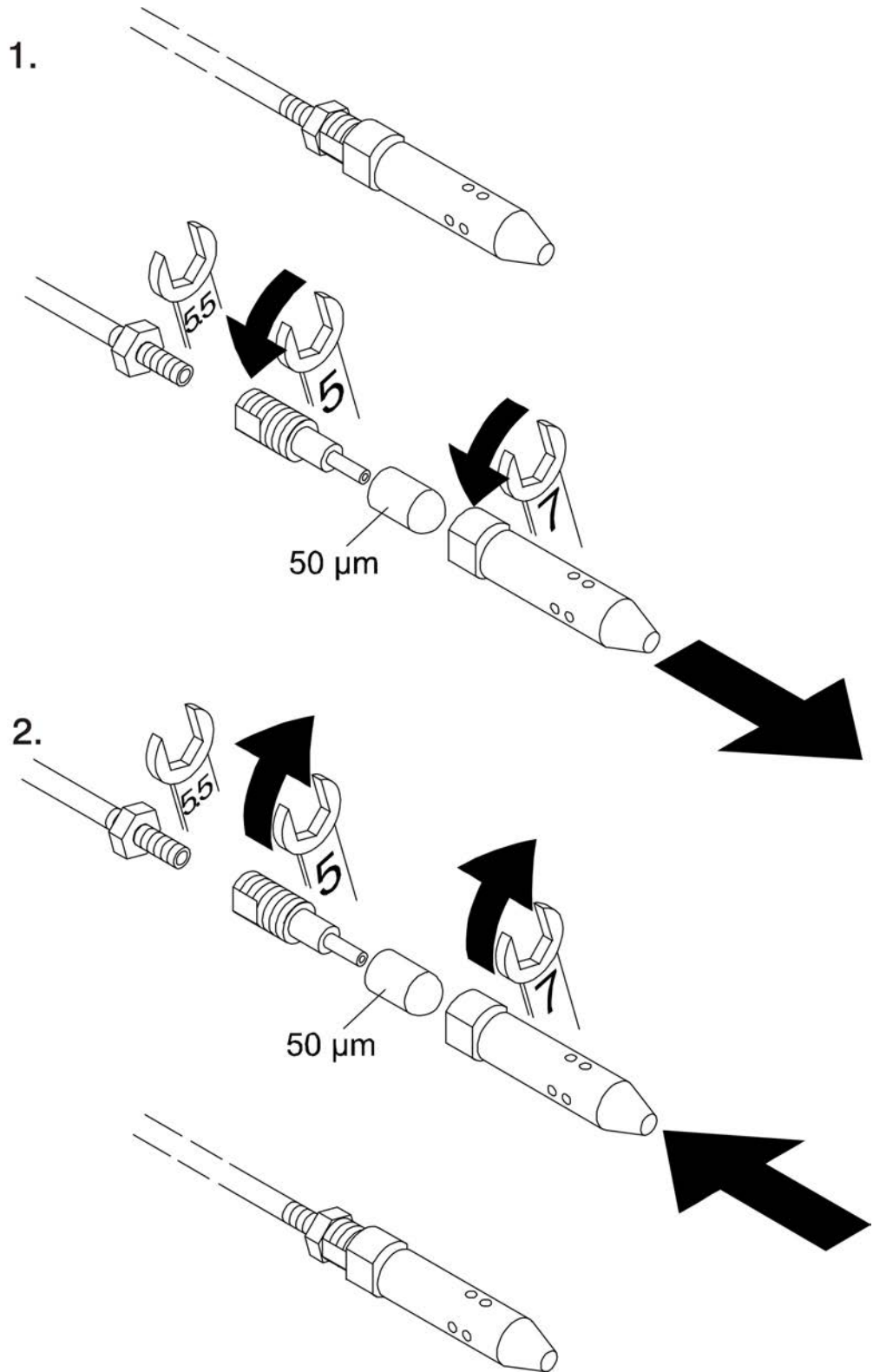

Spare filters available (pack of 10)

8 Faults/Warnings

8.4.8 Check sample gas extraction device (GED) for permeability

1. Connect the probe

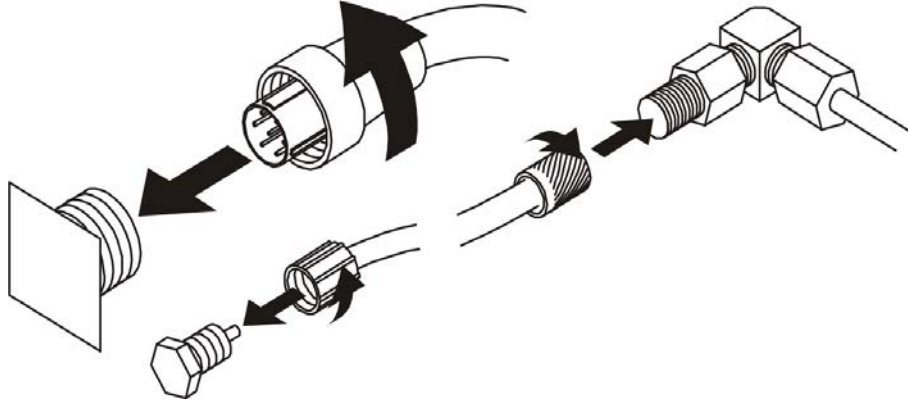

2. Select the operating mode: Measurement

- 3.

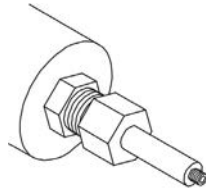

- 4.

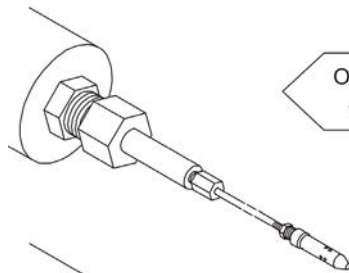

- 5.

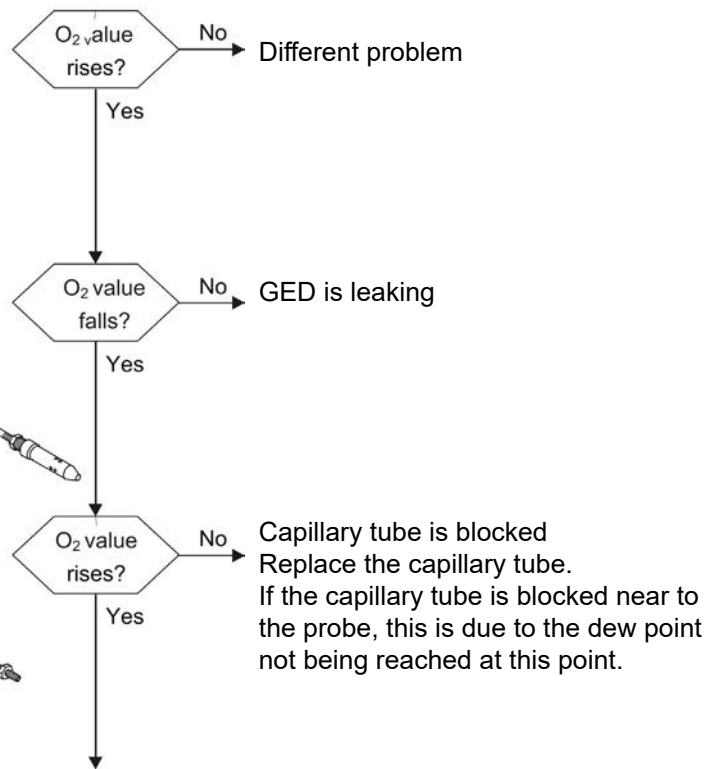
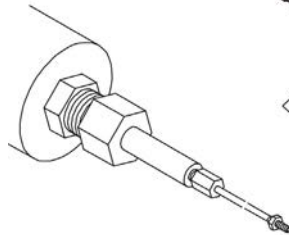

Sampling element is blocked

8.4.9 Clean the PIF Preliminary Filter

If the warning "Sintered metal preliminary filter dirty" appears:

- 1 Check quantity of calibrating gas (see chapter 8.4.4 *Change the Quantity of Calibrating Gas*)
Recommended setting:
 - Flowmeter 300 to 500 NI/h
 - Restrictor 1 to 5 mbar
- 2 Reduce the quantity of calibrating gas gradually
- 3 Reset warning
If it appears again, reduce the quantity of calibrating gas again.
- 4 If the quantity of calibrating gas is below 100 NI/h:
 - the PIF must be removed, and
 - the preliminary filter must be cleaned or replaced
Spare: Filter element for PIF, order no. 655R0212.

NOTICE

- Factory setting for the absolute pressure limit value: 50 mbar.
- The increase in pressure from the last calibration can be displayed for comparison by means of parameter 50.
- Factory setting for the absolute pressure limit value: 50 mbar



Calibrating gas feed

Water gas channel

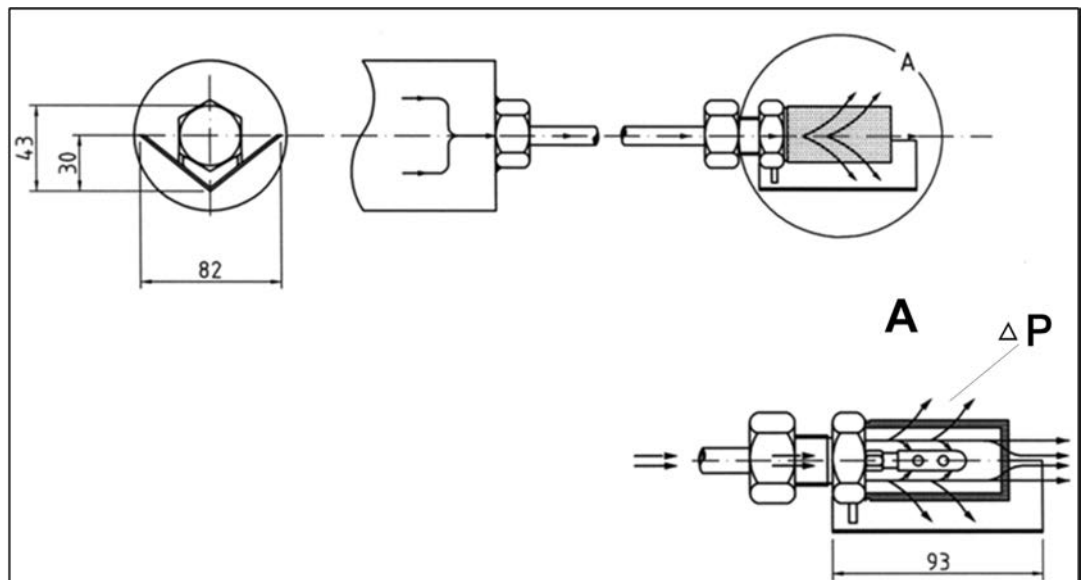

Sintered metal preliminary filter
type 655R0212

8 Faults/Warnings

8.4.10 Checking the Probe Heating System

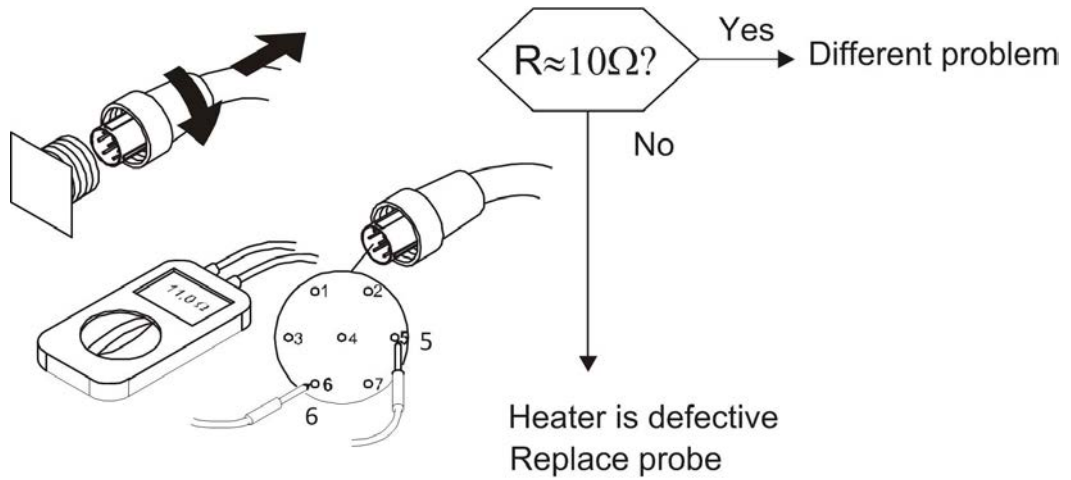

8.4.11 Checking the GED Heating System

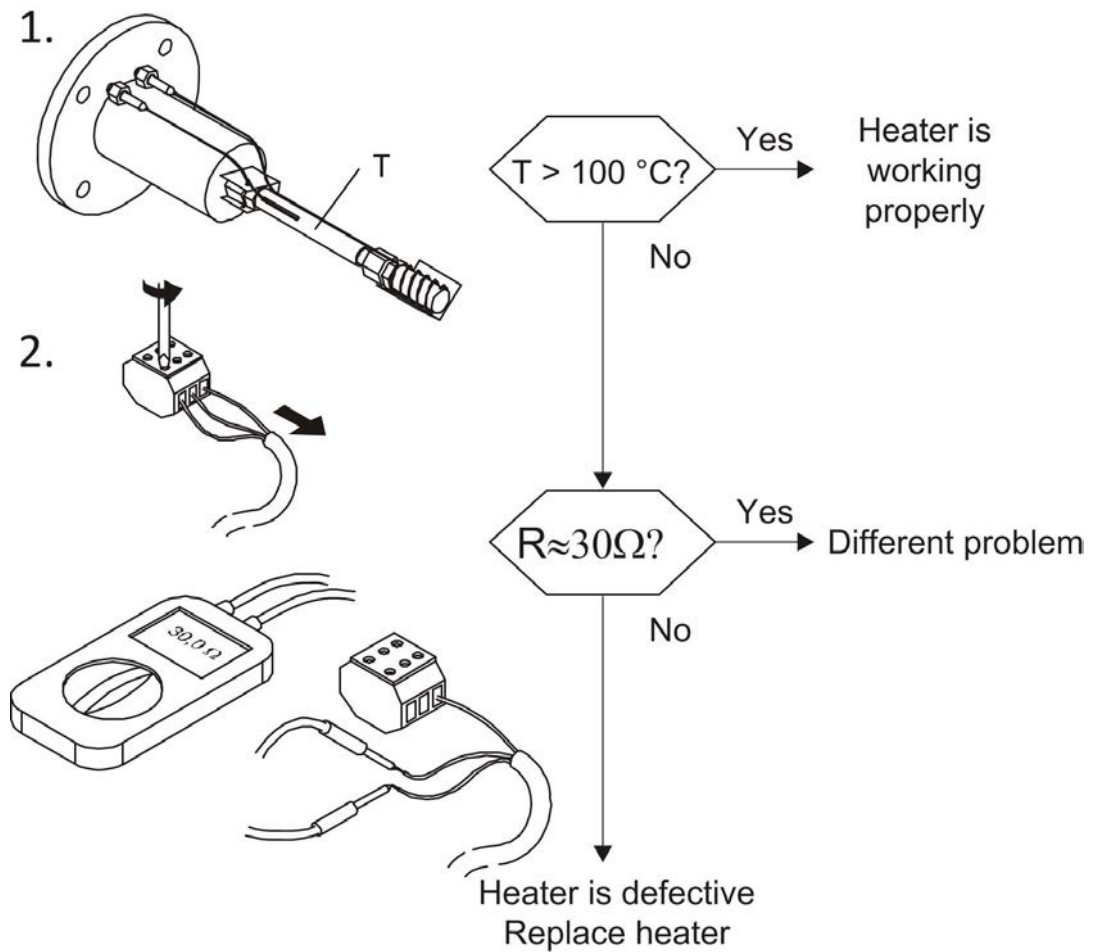

8 Faults/Warnings

8.4.12 Checking the Preliminary Filter Heating System

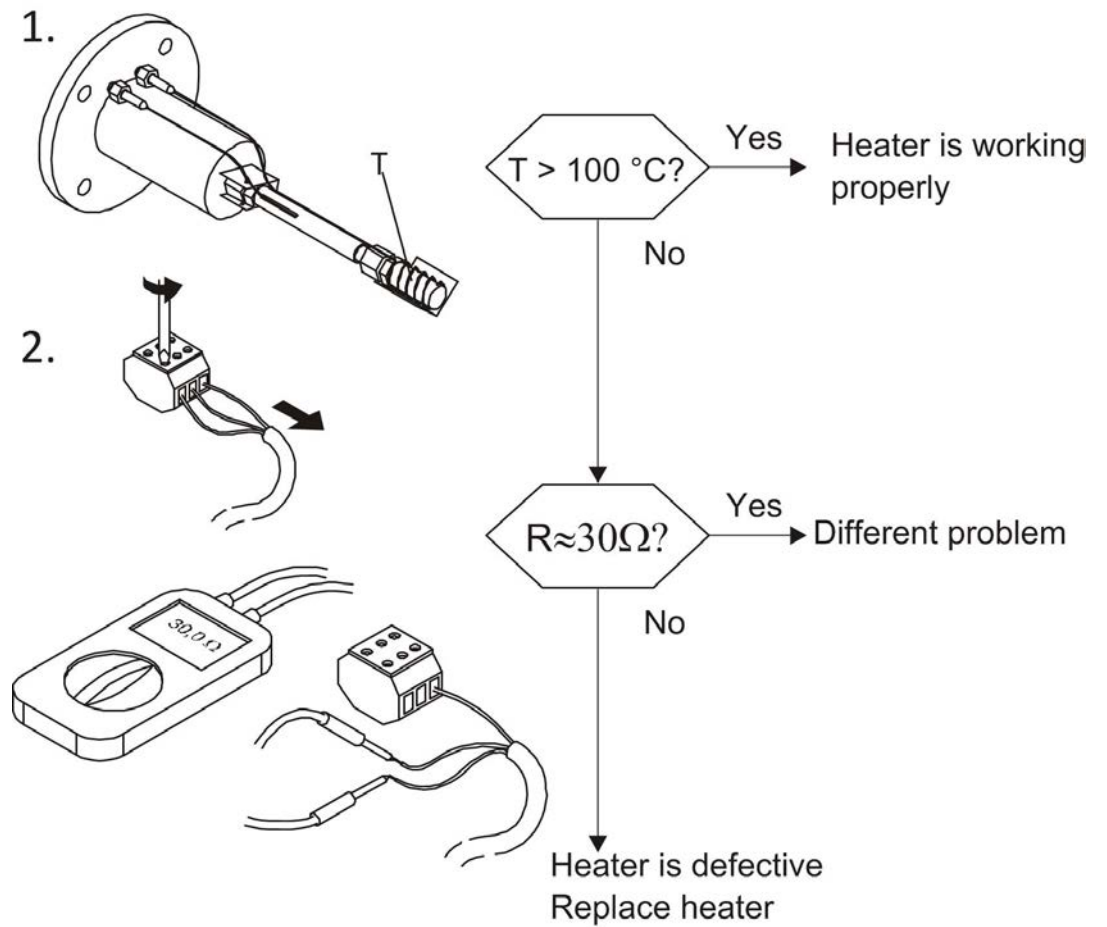

8.4.13 Removing the GED Heating System

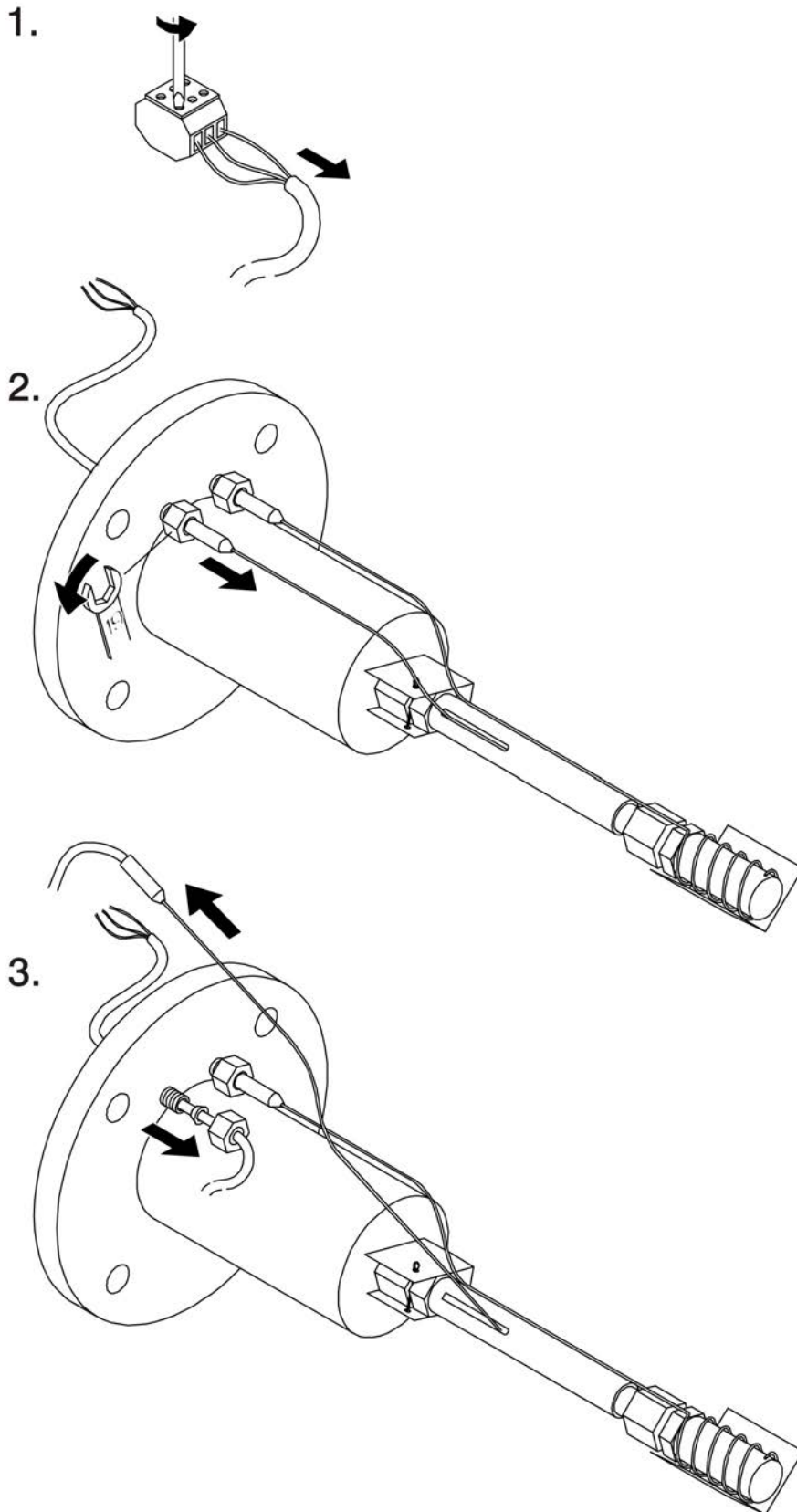

8.4.14 Installing the GED Heating System

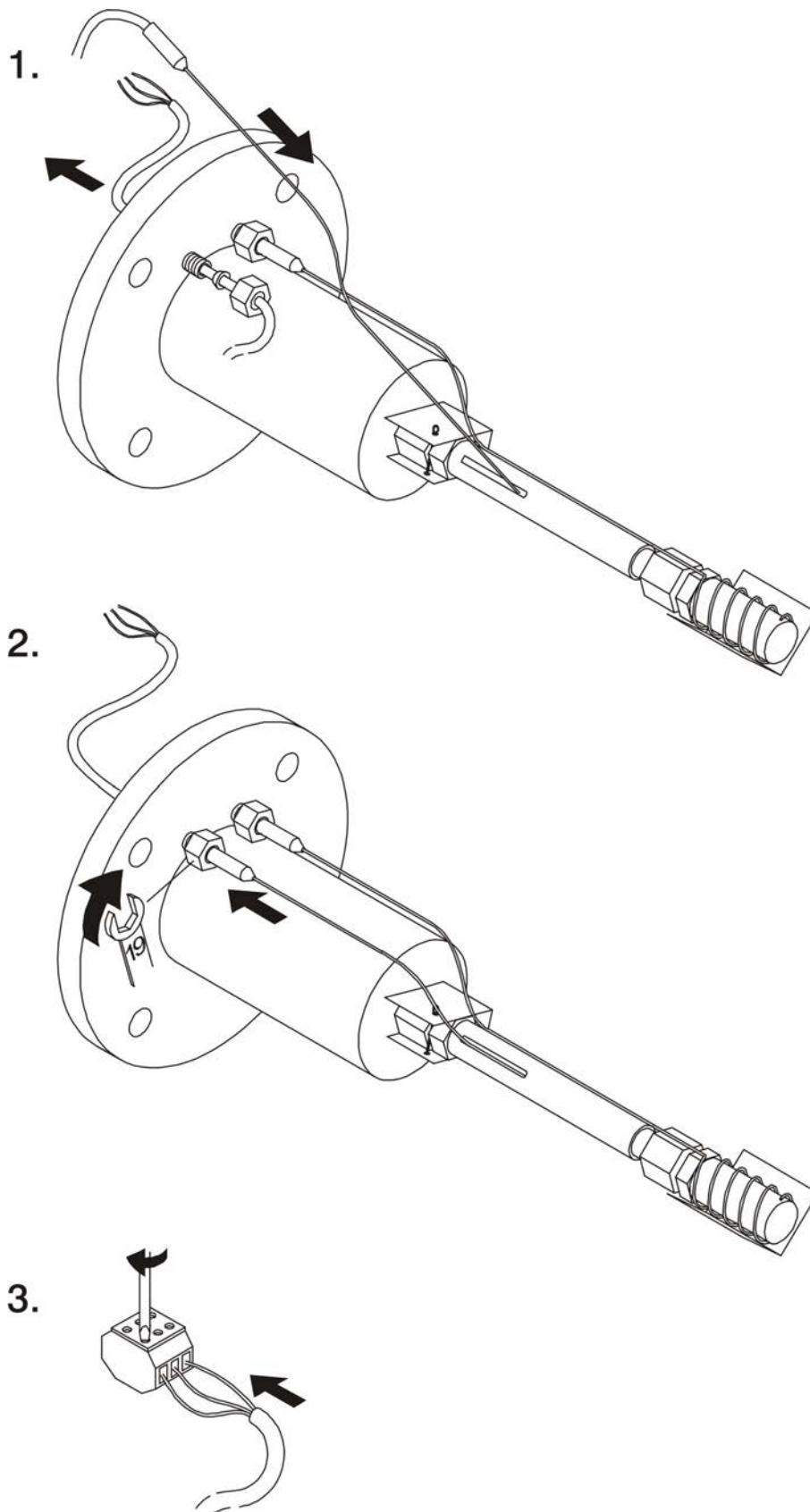

8.4.15 Removing the Preliminary Filter Heating System

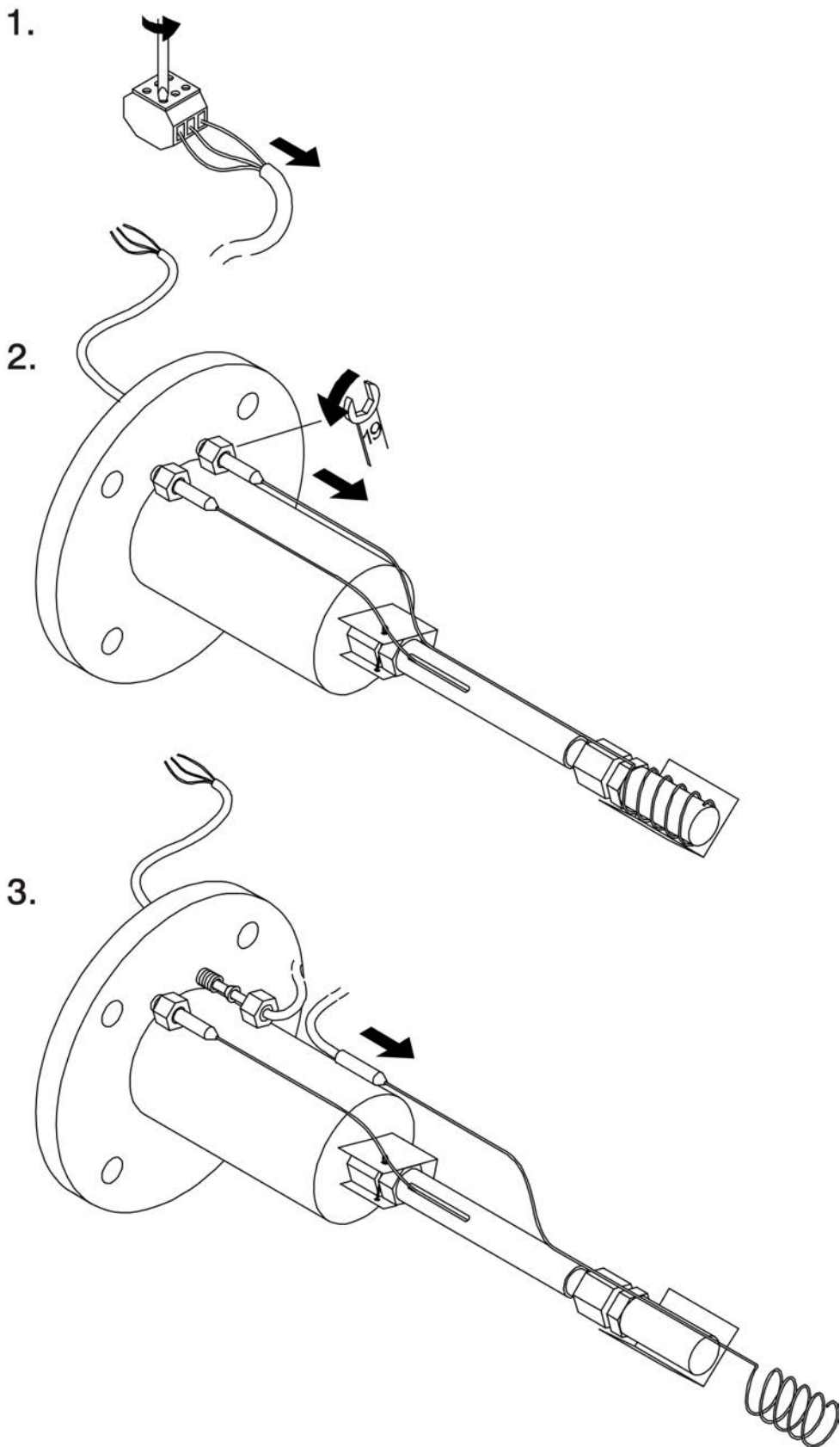

8.4.16 Installing the Preliminary Filter Heating System

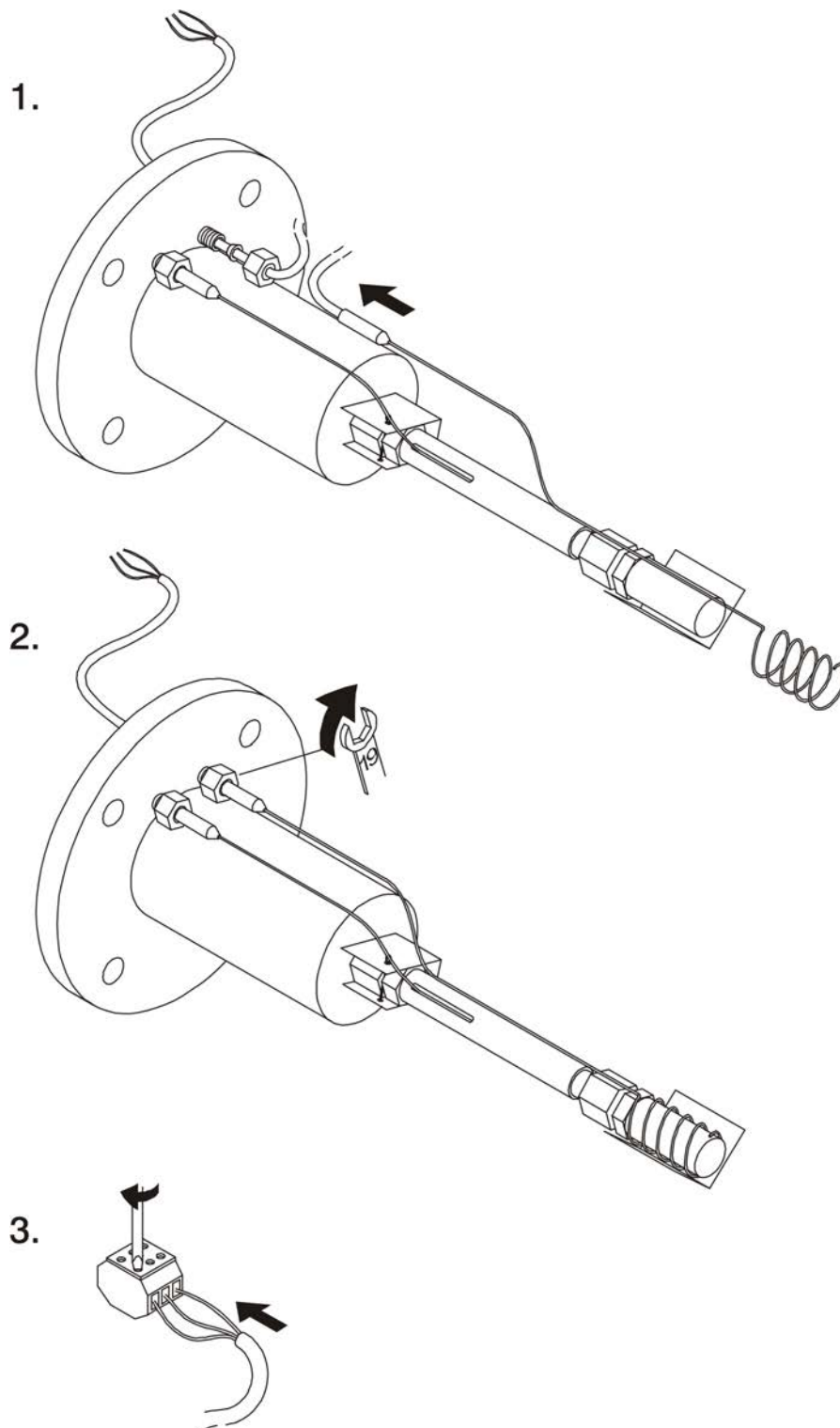

9 Appendix

9 Appendix

9.1 Connection Diagrams

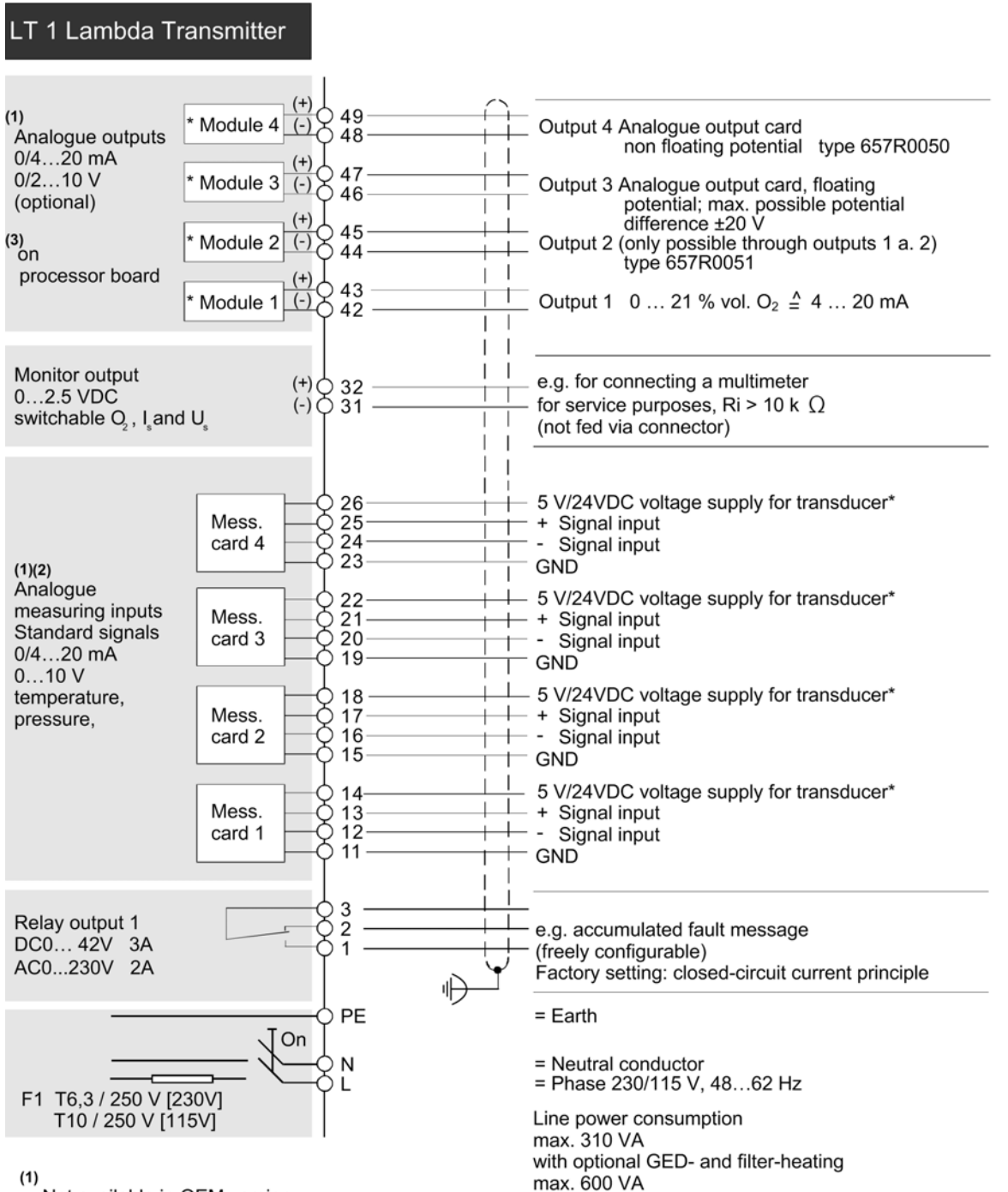

- (1) Not available in OEM version
 (2) Other levels/signal inputs possible, depending on measuring card. Max. 2 hereof floating potential; max. possible potential difference ± 20 V
 (3) Max. 2 hereof floating potential; max. possible potential difference ± 20 V

Fig. 9-1 Connecting diagram Lambda TransmitterLT1

NOTICE

Fuse replacement F1/F3 when changeover 230/115 VAC necessary !

9 Appendix

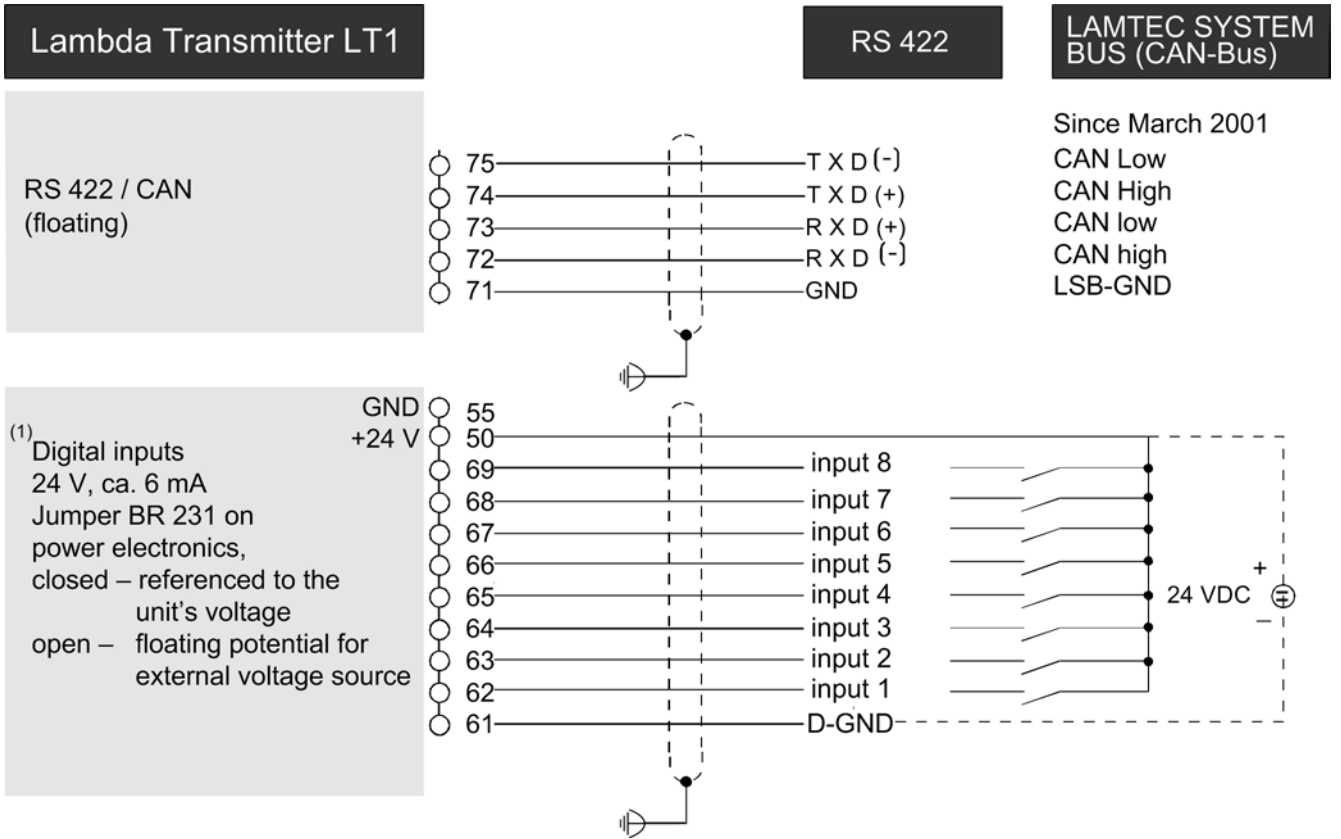

Fig. 9-2 Connecting diagram of the digital outputs, valid since March 2001

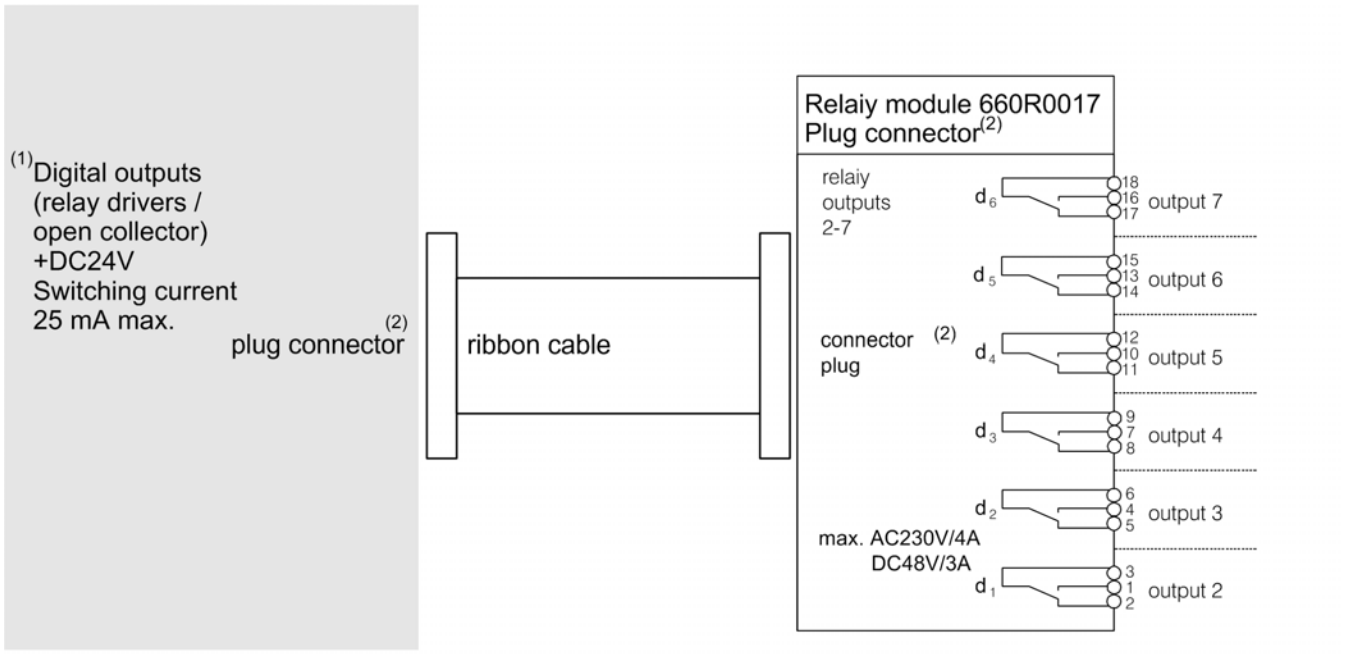
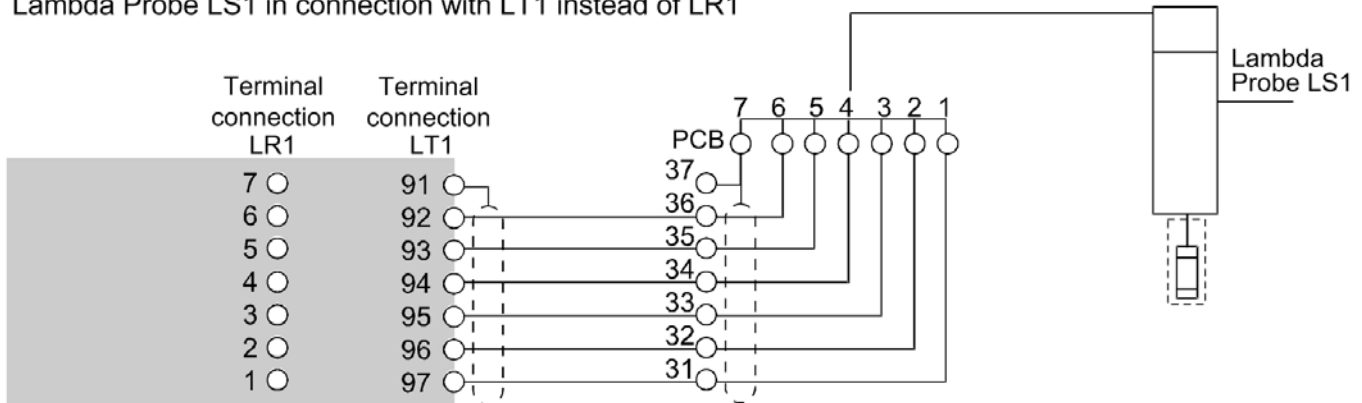

Fig. 9-3 Connecting diagram digital outputs

9 Appendix

Lambda Probe LS1 in connection with LT1 instead of LR1



Analogue Outputs Electrically Isolated - type 657R0053 (optional)

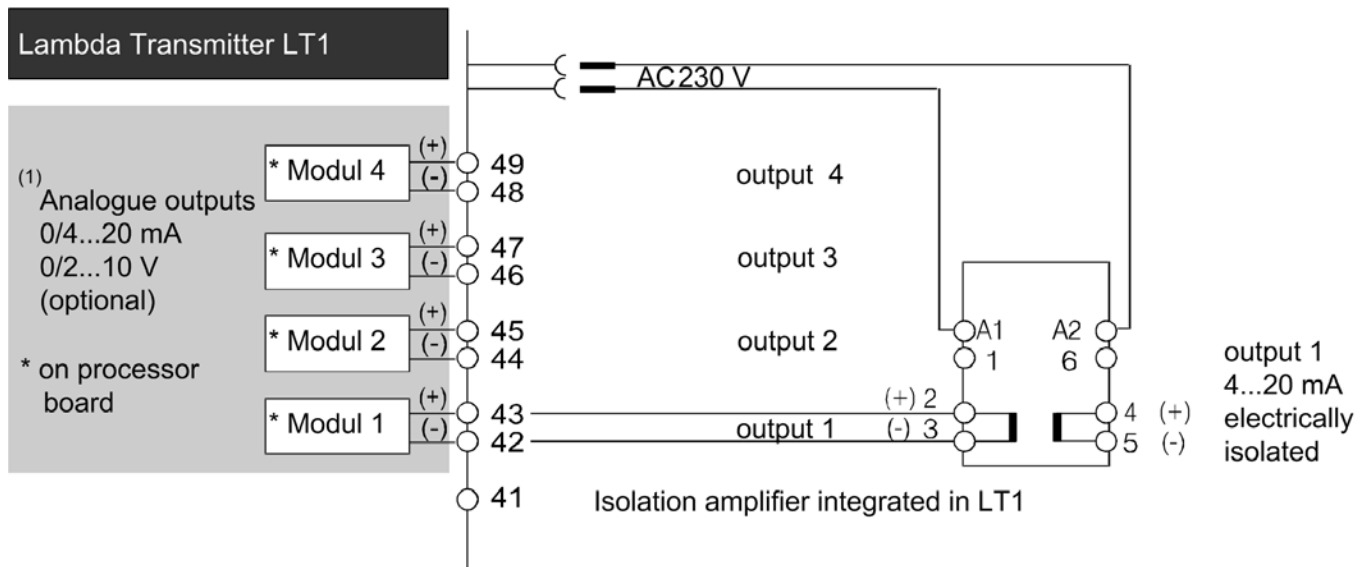

Analogue Inputs Terminals 11 to 26 – Connection variable

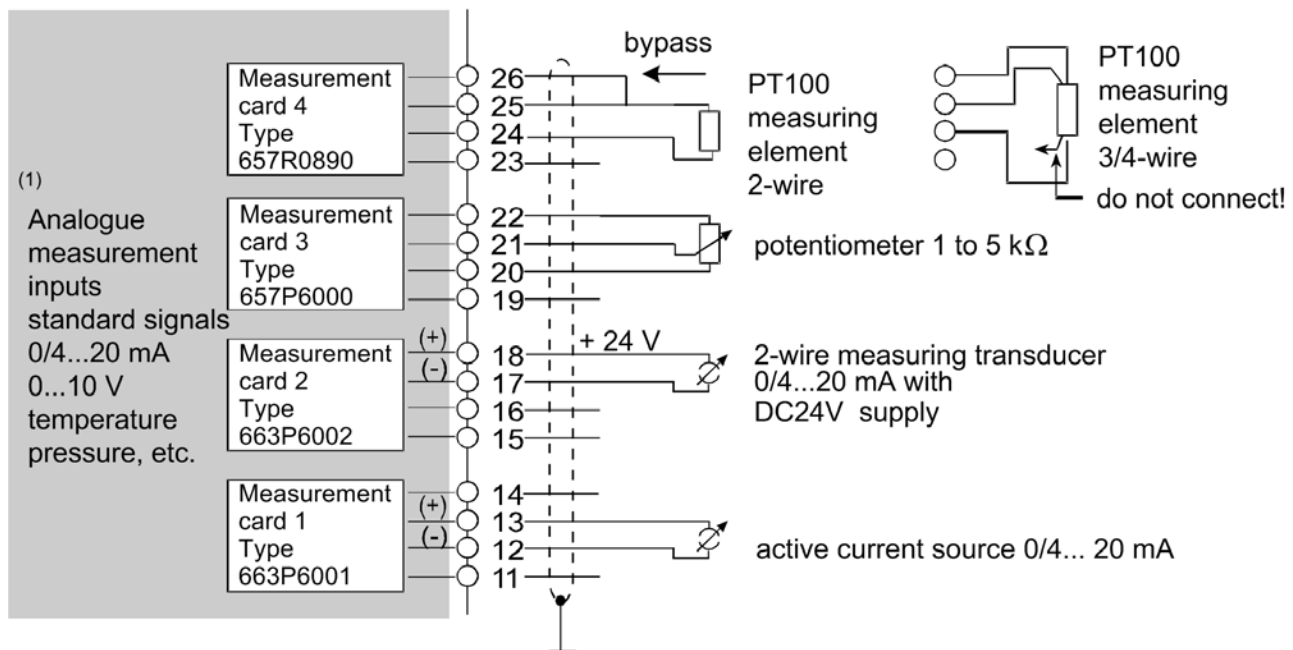

Fig. 9-4 Connection example: analogue inputs and outputs

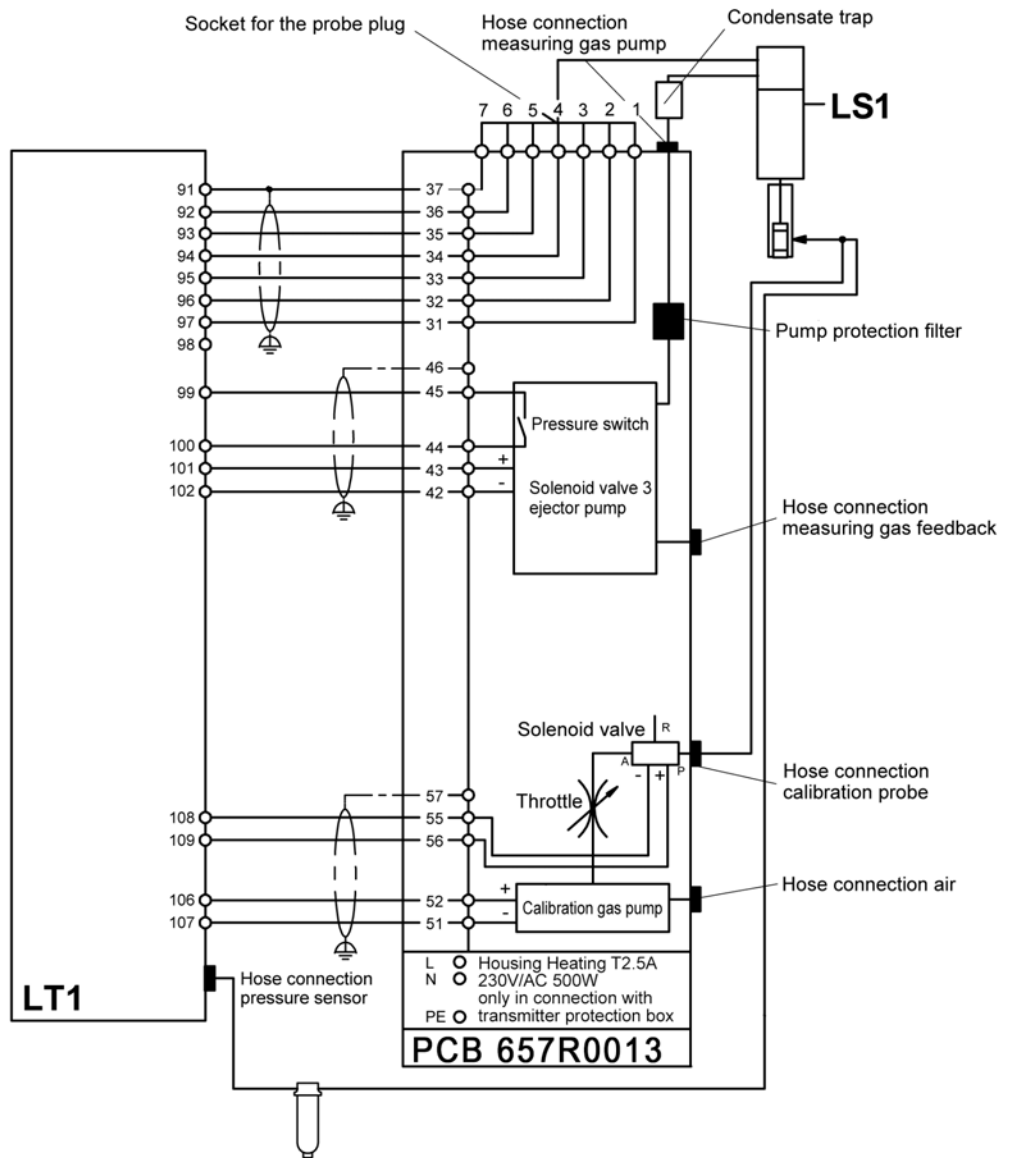
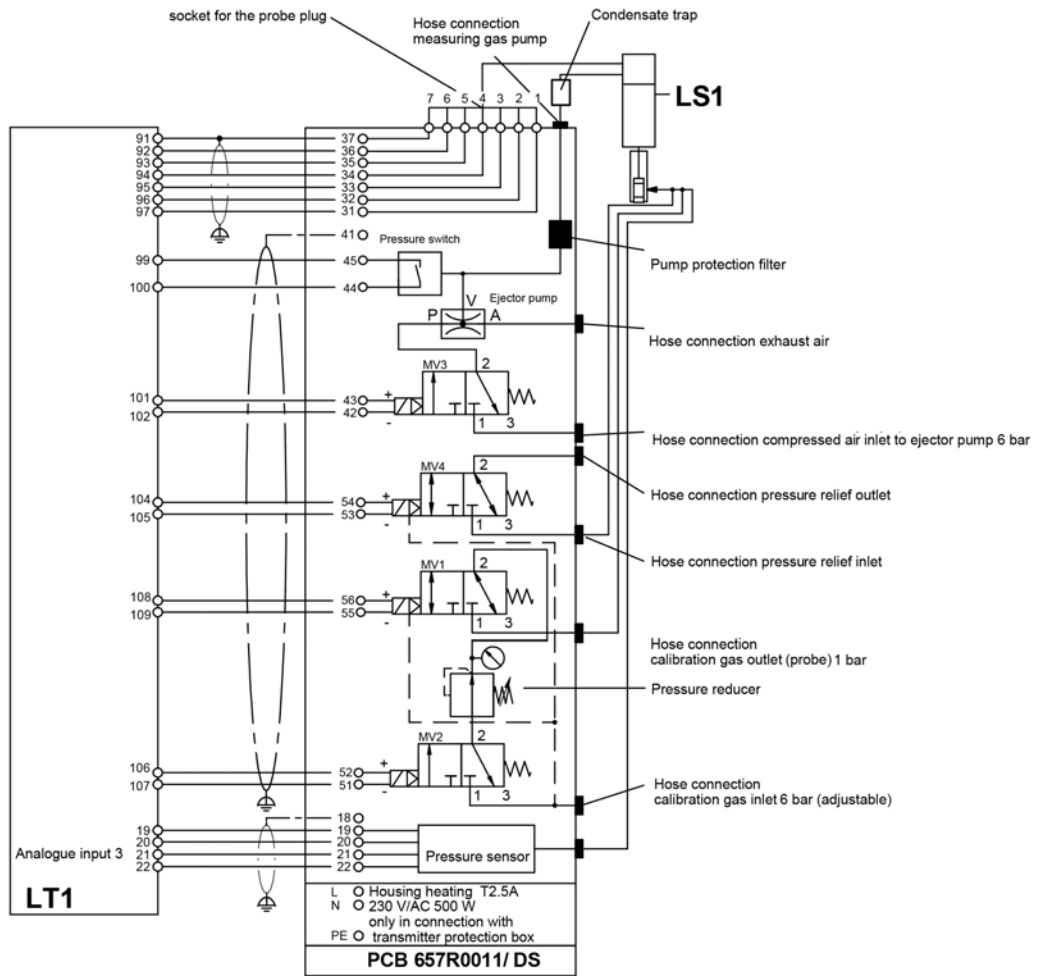

Fig. 9-5 Connecting diagram LT1 in conjunction with a probe connection box (PCB) 657R0013

NOTICE

The wiring diagram suitable for your application can be found on the inside of the SAK. If you need the wiring diagram in advance, you can request it by e-mail with reference to the order number.



Cable cross-sections for terminals
35, 36 (Probe heater)

Cable length SAK-LT1	Cross-section
up to 10 m	1.5 mm ²
up to 20 m	2.5 mm ²
up to 30 m	4.0 mm ²

all other cross-sections:
up to 10 m: 0.5 mm²/more than 10 m: 0.75 mm²

Fig. 9-6 Connecting diagram LT1 in conjunction with a probe connection box (PCB) 657R0011-DS, represent the connection of further options used in the PCB

NOTICE

The wiring diagram suitable for your application can be found on the inside of the SAK. If you need the wiring diagram in advance, you can request it by e-mail with reference to the order number.

9.2 Basic Printed Circuit Board

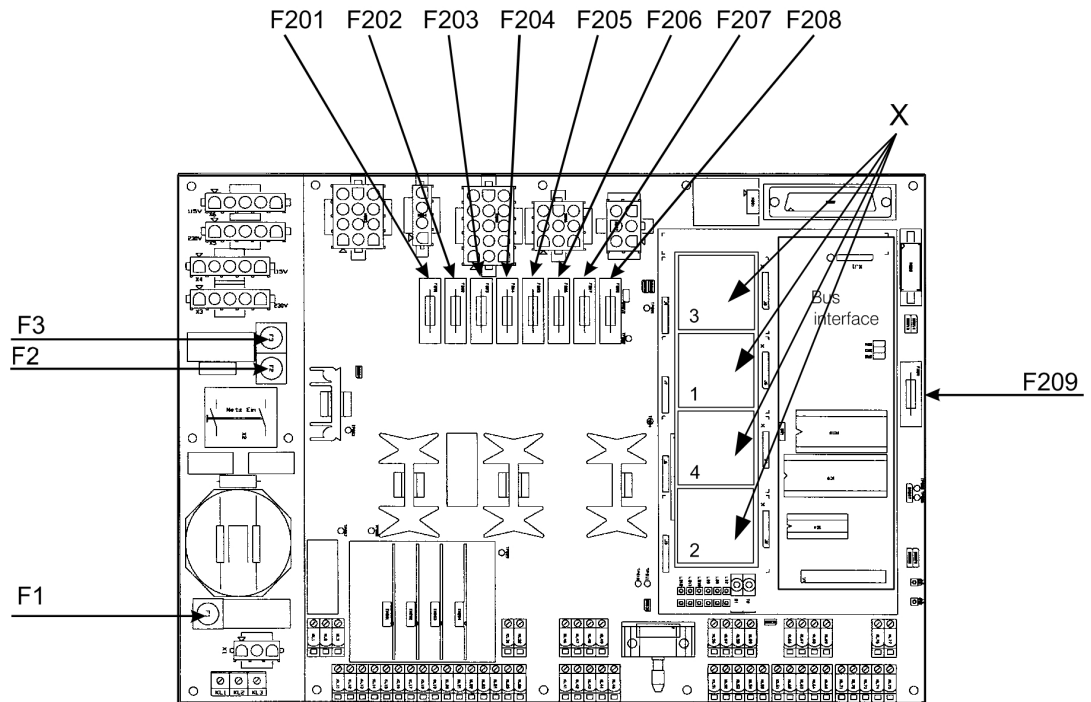

Fig. 9-7 Fuses till serial no.: 0599, X - Analogue output module

Fuse ratings:	F 1	F 2	F 3	F 201	F 202	F 203	F 204	F 205	F 206	F 207	F 208	F 209
	6,3 A	2,5 A	2,5 A	6,3 A	1 A	3,15 A	1 A	1 A	4 A	4 A	1,5 A	375 mA
	10 A	5 A	5 A	delayed-action	delayed-action	delayed-action	delayed-action	delayed-action	delayed-action	delayed-action	delayed-action	delayed-action
				Calibrating gas pump	Solenoid valves	Measured gas pump	24 V	+ / - 5 V processor, analogue section	Probe heating (control)	Probe heating (fixed voltage)	Probe current supply (variable voltage)	RS 422 / RS 485 (potential-free)
				Main fuse, power supply input for 230 V power supply voltage for 115 V power supply voltage	Transformer, GED and pre-filter heating for 230 V power supply voltage for 115 V power supply voltage	Transformer, electronics for 230 V power supply voltage for 115 V power supply voltage						

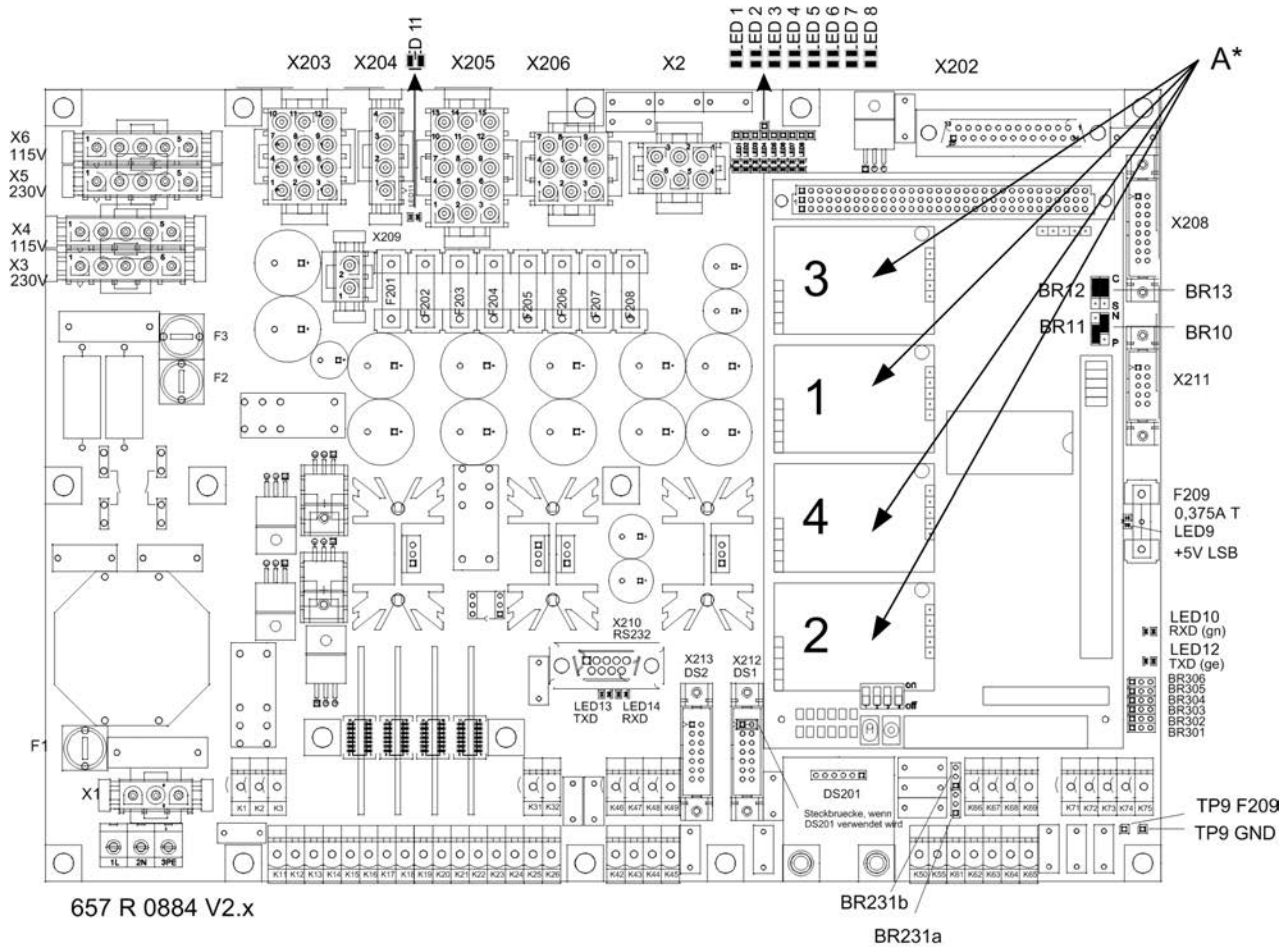

Fig. 9-8 Fuses from Serial no.: 0600

Description of the LEDs, Fuses, Jumpers, new Connectors and Terminals

LEDs

LED 1 green	monitoring supply voltage +12 VDC calibration gas pump	F201 6,3Atr
LED 2 green	monitoring supply voltage +12 VDC solenoid valves	F202 1,5Atr (1,6Atr)
LED 3 green	monitoring supply voltage +12 VAC measuring gas pump	F203 3,15Atr
LED 4 green	monitoring supply voltage +24 VDC	F204 0,8Atr
LED 5 green	monitoring supply voltage +5 VDC digital circuit	F205 1,5Atr(1,6Atr)
LED 6 green	monitoring supply voltage +5 VDC digital circuit	without fuse
LED 7 green	monitoring supply voltage +5 VDC analogue circuit	without fuse
without LED	probe heater (control)	F206 4Atr

Terminals

Terminals 71 - 75 configured for the LAMTEC SYSTEM BUS have the following meaning:
 KL71: CAN-GND (n.c.)
 KL72: CAN-H
 KL73: CAN-L
 KL74: CAN-H
 KL75: CAN-L

9 Appendix

without LED	probe heater (fixed voltage)	F207 4Atr
LED 8 green	monitoring supply voltage +6 VDC Voltage	F208 1,5Atr(1,6Atr)
LED 9 green	monitoring supply voltage +5 VDC LSB or RS422	F209 0,375Atr
LED 10 green	status of pump pressure switch (on = switch on = low pressure available)	Fuse rating
LED 11 yellow	LSB or RS422 RxD-LED	F201 ... F209 according to IEC 60127-2/5 or IEC 60127-2/3
LED 12 yellow	LSB or RS422 TxD-LED	
LED 13 yellow	integrated RS232 TxD-LED	
LED 14 yellow	integrated RS 232 RxD-LED	

9 Appendix

Fuse ratings F1 ... F3 according to IEC 60127-2/5:	F 1	6,3 A	delayed-	Main fuse, power supply input for 230 VAC power supply voltage for 115 VAC power supply voltage
		10 A	action	
			delayed-	
	F 2	2,5 A	delayed-	Transformer, GED and pre-filter heating for 230 VAC power supply voltage for 115 VAC power supply voltage
		5 A	action	
			delayed-	
	F 3	2,5 A	delayed-	Transformer, electronics for 230 VAC power supply voltage for 115 VAC power supply voltage
		5 A	action	
			delayed-	
			action	

NOTICE

Fuse replacement F1/F3 when changeover 230/115 VAC necessary !

Jumpers Both jumpers in position 1-2 (down). Digital inputs in reference to device GND
BR231A and Both jumpers in position 2-3 (above). Digital inputs are floating, for external GND
BR231B

BR302-BR306 Position 1-2 (left). Configuration for LAMTEC-SYSTEM-BUS (CAN)
Position 2-3 (right). Configuration for RS 422-Interface (SICK)

BR301 Position 1-2 (left). Without termination, no end device
Position 2-3 (right). With 120 Ω termination, for end device

Setting for RS422 Interface on 2-3, it means for RS 422 communication the whole Jumpers BR301 BR306 are in right position (2-3)

New Connectors

X210 Integrated RS232 Interface



X211 Relay module with Watchdog-Signal

X212 Connector for pressure sensor module 1.
On to this connector can be fixed in future a pressure sensor module with the small pressure sensor.
It replaces then the big DS 201 pressure sensor. In case of the use of the big pressure sensor, the pins 1 and 2 of this connector are to be jumpered.

9.3 Analogue Output Card

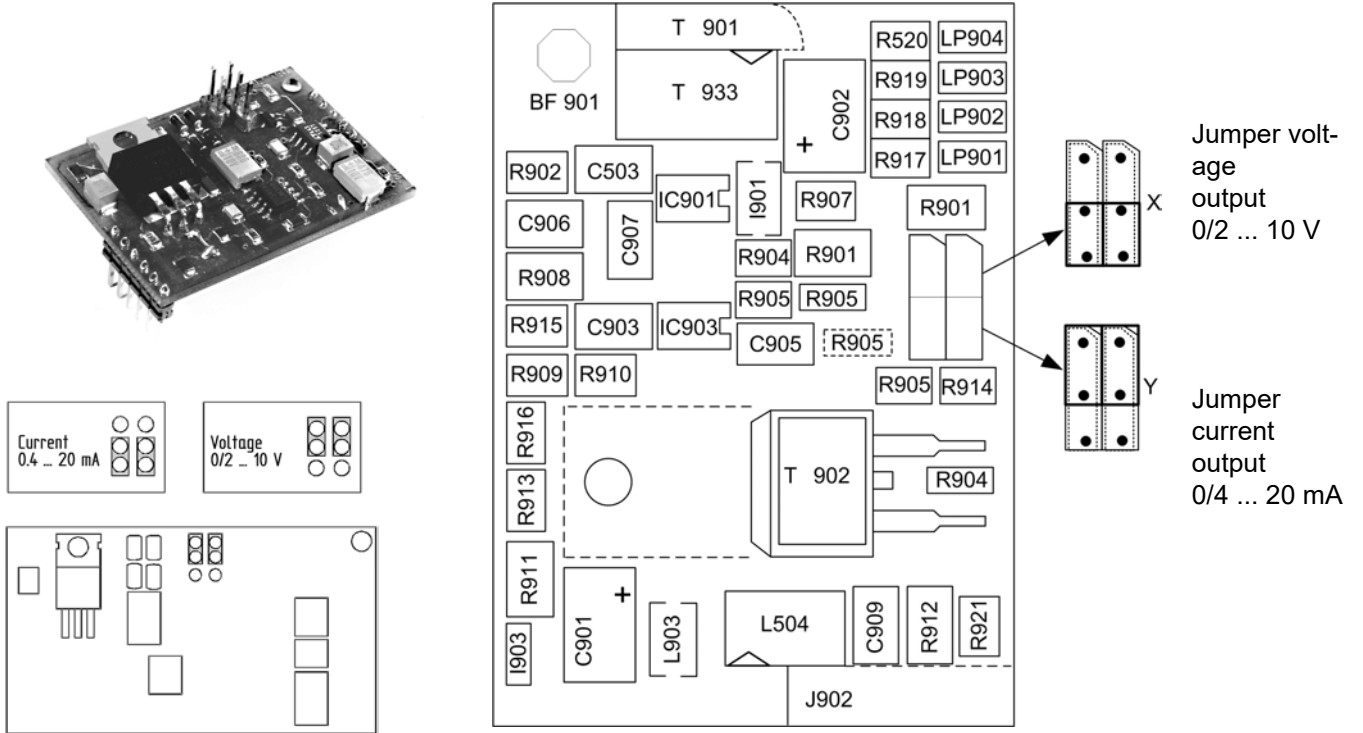
0/4 ... 20 mA, 0/2 ... 10 V (optional Type 657R0005 - non-floating (1 channel)
 (Not possible with OEM design)
 Can be retrofitted on LT1 processor board (max. 4 cards).



The analogue output cards must be activated.



 Parameter 532 - 564

9.4 Other Details, Dimensions

Ambient temperature:

- LT1 with measuring gas pump +5 °C ... +45 °C | +41 °F ... 113 °F, short-term up to +60 °C | +140 °F
- LT1 without measuring and calibrating gas pump -20 °C ... +60 °C | -4 °F ... +140 °F

Type 657R0020 ... 0029

Wall-mounting housing IP54 with display and operating unit (optional)

Installation under protecting shed
Ambient temperature 0 °C bis +60 °C | 32 °F ... 140 °F

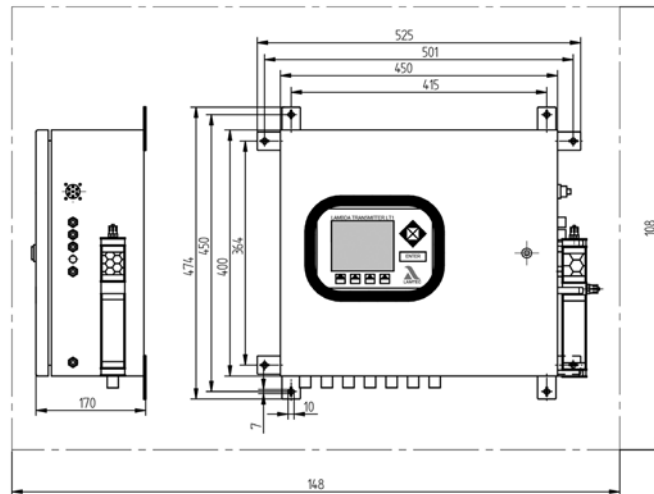

Type 657R0045 / R0046

With option 657R0049
19"-panel-mounted housing
With display and operating unit

Installation frame (h x w):

172 mm x 482 mm | 6.77" in x 18.98" in

Panel cutout (h x w):

140 mm x 450 mm | 5.51" in x 17.72" in
depth: 320 mm | 12.6" in

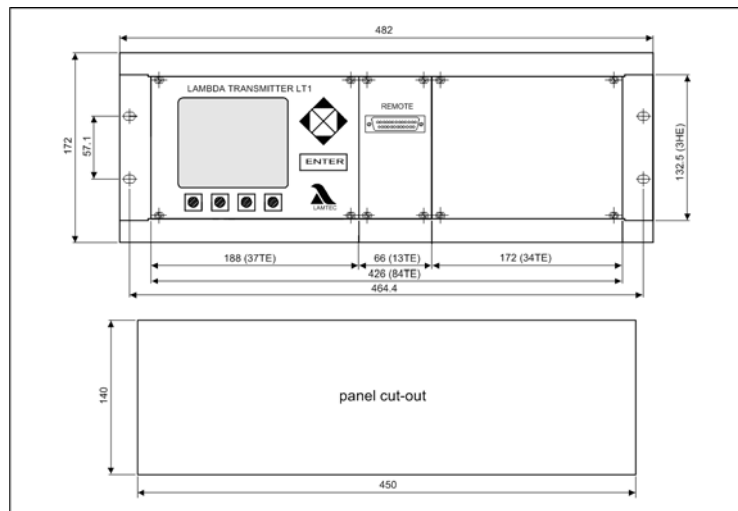

9 Appendix

9.5 Spare Parts

A list of relevant replacement parts is given below.

It is advisable to keep a stock of those parts marked with an asterisk (*).

Stocking of replacement parts marked ⁽¹⁾ is a matter of discretion.

Stocking of replacement parts marked ⁽²⁾ is appropriate only if the measurement system is equipped with the relevant option.

Consumables	
1 Lambda Probe LS1 Gas-tight version without gas extraction device (GED) replacement probe on request	650R0031... R0034, ⁽¹⁾
1 Set of seals for measured gas pump (diaphragm, valves, seals)	657R0215F ⁽¹⁾
1 Set of seals for measured gas pump for corrosive measured gases	657R0217F ⁽¹⁾
1 Protective pump filter (one-way filter) for calibrating gas pump	652R0210 ⁽¹⁾
1 Active carbon filter (one-way filter)	652R0248 ⁽¹⁾
1 Particle filter 0.1 µm, 98 % (one-way filter)	652R0250 ⁽¹⁾
1 Replacement filling 10er-Pack for PS-filter 657R0789/R0792	657R0791 ⁽¹⁾
Replacement parts	
1 Gas extraction device (GED) e.g. 1000 mm 39.37" in long length to be stated when ordering	655R0023 ⁽¹⁾
1 Extraction filter for GED	655R0028 ⁽¹⁾
1 Sintered metal filter insert, 50 µm (pack of 10) for extraction filter	655R2803 ⁽¹⁾
1 Filter attachment for probe installation fitting (PIF) - filter gauge 20 µm (Standard) - filter gauge 10 µm - filter gauge 40 µm - filter gauge 2 µm	655R0212 ⁽¹⁾ 655R0211 655R1210 655R0208
1 Replacement protective tube with GED-heater, for example for GED 800 mm 31.5" in long, only for connection to an external power supply unit	655R0701 ⁽³⁾
1 Replacement heater for GED 1000 mm 39.37" in long	655R0092 ⁽³⁾⁺⁽²⁾
1 Replacement heater for PIF filter attachment for GED 1000 mm / 39.37" in long	655R1092 ⁽³⁾⁺⁽²⁾
1 GED protective tube 1.4571 (V4A) 1000 mm 39.37" in long	655R0620 ⁽³⁾
1 GED protective tube, material 2.4610 for measured gas temperatures up to 800 °C 1472 °F, 1000 mm 39.37" in long	655R1620 ⁽³⁾
1 Insulation fabrics inside for probe installation fitting (PIF) 655R0037/1137/0083/1183	655P3705 ⁽²⁾
1 Insulation fabrics outside for probe installation fitting (PIF)	657P0100 ⁽¹⁾
1 Moulded insulating part, internal, for probe installation fittings (PIF)655R0037/1137/0083/1183	655P3705 ⁽²⁾
1 Moulded insulating part, internal, for probe installation fittings (PIF)	657P0100 ⁽¹⁾
1 Temperature sensor Pt100 for LS1	657P0454 ⁽³⁾
1 Blind flange PIF/LS1, 8 hole	657P0445
1 Flange seal for LS1, probe installation fitting (PIF), graphite	650R0910 ⁽¹⁾
1 Repair kit, "critical nozzle"	650R0900 ⁽¹⁾
1 Measured gas pump 112 VDC, tap position Dn D incl. vibration damper with collector motor Measured gas pump 12 VDC for corrosive flue gases, connection position D incl. vibration damper LT built since 2014	657R0872 ⁽¹⁾ -old 657R0836 -old
1 Measured gas pump 112 VDC, tap position Dn D incl. vibration damper with collector motor alternative: Measured gas pump 12 VDC for corrosive flue gases, connection position D incl. vibration damper	657R0936 657R0937

9 Appendix

Replacement parts

1 Pump head for aggressive flue gases with moulded diaphragm	652R0205F ⁽²⁾
1 Pump head, complete with moulded diaphragm	652R0204F ⁽¹⁾
1 Protective pump filter for measured gas pump - replaceable filling	657R0789 ⁽¹⁾
1 Condensate collector with integral pump protection filter (replaceable filling)	657R0792
1 Calibrating gas pump 12 VDC, incl. vibration damper	657R0837 ⁽¹⁾
1 Absolute pressure sensor, standard	657P0416
1 Mounting paste (anti-burn-in paste), pack of 5	650R1090 ⁽¹⁾
1 Box of assorted small parts for LT1	657R0305 ⁽¹⁾
1 Replacement display and operating unit	657R0829 ⁽¹⁾
1 Replacement power electronics (full version)	657R0884 ⁽¹⁾
1 Replacement computer electronics (new option, without EPROM)	657R1874 LT1 ⁽²⁾
1 LT1 power supply unit (transformer)	657R3871 ⁽¹⁾
1 Replacement electronic external power supply unit 657R0915 for GED and filter heating up to 1600 mm 62.99" in	657R3165V2.0V
1 Replacement electronic external power supply unit 657R0815 for GED and filter heating up to 800 mm 31.5" in	657R3165V ⁽²⁾
1 Analogue output card 0/4...20 mA; 0 ... 10 V (1 channel)	657R0050 ⁽²⁾
1 Analogue output card 0/4 ... 20 mA; 0 ... 10 V potential-free, max. potential difference ± 20 V	657R0051 ⁽²⁾
1 Relay module for digital outputs with 6 relays (one switch over contact) for output of operation and status messages	660R0017 ⁽²⁾
1 Universal module for analogue input potentiometer 1 ... 5 k Ω	657P6000 ⁽²⁾
1 Universal module for analogue inputs 0/4 ... 20mA	663P6001 ⁽²⁾
1 Universal module for analogue input 0.4 ... 20 mA with 24 VDC feed for transducer	663P6002 ⁽²⁾
1 Temperature input for Pt100, specify measuring range	657R0890 ⁽¹⁾
1 Temperature sensor Pt100, 250 mm 9.84" in long	657R0891 ⁽¹⁾
1 Temperature sensor Pt100, 150 mm 5.91" in long	657R0897 ⁽¹⁾
1 Interface module RS422	663P0500 ⁽²⁾
1 Interface module RS232 (upon request)	663P0600 ⁽²⁾
1 Serial connecting lead, 9-pole Sub-D Socket/socket 10 m 32.81 ft long	663R0100 ⁽²⁾
1 Extension for serial connecting lead, 9-pole Sub-D Socket/plug connector, 10 m 32.81 ft long	663R0101 ⁽²⁾

9.6 EU Declaration of Conformity



EU-Konformitätserklärung

EU Declaration of Conformity
Déclaration de Conformité UE

Wir
We
Nous

LAMTEC Meß- und Regeltechnik für Feuerungen GmbH & Co. KG
Josef-Reiert-Straße 26
D-69190 Walldorf (Baden)

erklären,
dass das Produkt
declare that product
déclarons que produit

LT1 – Lambda Transmitter

Bestehend aus
consisting of
composé de

LT1 im Wandaufbaugehäuse 657R002
LT1 in wall mounting housing
LT1 dans coffret mural

LS1 Sonde 650R0004
LS1 probe 650R0034
LS1 sonde

inklusive
inclusive
y compris

Sondenanschlusskasten SAK 657R001X
Probe connection box PCB
Bôîtier de raccordement de sondes BRS

LAMTEC Meß- und Regeltechnik für Feuerungen
GmbH & Co. KG
Josef-Reiert-Straße 26
D-69190 Walldorf (Baden)

Telefon: +49 6227 6052-0
Telefax: +49 6227 6052-57

Internet: www.lamtec.de
E-Mail: info@lamtec.de

print 12/01/23

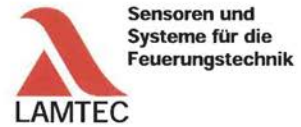

auf welche sich diese Erklärung bezieht, mit den folgenden Norm(en) übereinstimmt
 to which this declaration relates conforms to the following standard(s)
 sur laquelle cette déclaration se réfère, et conformément aux dispositions de la norme(s)

DIN EN 61326-1: 2013-07
 DIN EN 61010-1: 2020-03

gemäß den einschlägigen Harmonisierungsrechtsvorschriften der Europäischen Union:
 in accordance with the relevant harmonization legislation of the European Union:
 conformément à la législation d'harmonisation pertinente de l'Union européenne:

Nummer (Number / Numéro)	Text (Text / Texte)
2014/35/EU 2014/35/EU 2014/35/UE	Niederspannungsrichtlinie Low Voltage Directive Directive basse tension
2014/30/EU 2014/30/EU 2014/30/UE	EMV-Richtlinie EMC Directive Directive CEM
2011/65/EU 2011/65/EU 2011/65/UE	RoHS RoHS RoHS

Das Datenblatt und gegebenenfalls die zugehörige Dokumentation sind zu beachten.
 (The data sheet and basic documentation, if any, have to be considered.)
 (La consultation de la fiche technique, et éventuellement de la documentation technique de base, est requise.)

Die alleinige Verantwortung für die Ausstellung dieser Konformitätserklärung trägt der Hersteller.
 The manufacturer is solely responsible for issuing this declaration of conformity.
 Seul le fabricant est responsable de la délivrance de cette déclaration de conformité.

Rechtsverbindliche Unterschrift
 Authorized signature / Signature autorisée

Walldorf, 01.09.2022
 H.-J. Altendorf, General Manager

LAMTEC Meß- und Regeltechnik für Feuerungen
 GmbH & Co. KG
 Josef-Reiert-Straße 26
 D-69190 Walldorf (Baden)

Telefon: +49 6227 6052-0
 Telefax: +49 6227 6052-57

Internet: www.lamtec.de
 E-Mail: info@lamtec.de

print 12/01/23

9.7 SIL Manufacturer Declaration



SIL Manufacturer declaration
Functional Safety according to DIN EN 61508

Product: LT1 Lambda Transmitter with O₂ measurement transducer LS1 Lambda Probe
Version: Hardware V2.6 and Software V5.025

Manufacturer declaration:

We hereby declare that the above-mentioned product is suitable for use in safety-related applications in accordance with DIN EN 61508:2011 for combustion engineering applications.

The corresponding safety manual must be taken into account.
("SO-Safety-Manual-LT1-DLT6040-18-aEN-001.pdf")

For the combination of the LT1 Lambda Transmitter with the LS1 O₂ transducer, the following values were determined in accordance with DIN EN 61508 Ed. 2.0 in combination with the fully automatic adjustment unit (LAMTEC article 657R0800):

Fuel	Gas and Oil	Heavy Fuel Oil	Special Fuels
SIL	SIL 1	SIL 1	SIL 1
SFF	97.39%	98.27%	98.70%
DC _{AVG}	73.60%	81.33%	85.45%
PFH	6.35E-07	8.49E-07	1.26E-06
PFD _{AVG}	2.35E-02	2.46E-02	2.47E-02

LAMTEC Meß- und Regeltechnik
für Feuerungen GmbH & Co. KG
Wiesenstraße 6 (Gewerbegebiet Impex)
D-69190 Walldorf (Baden)
Tel.: 06227 / 6052-0, Fax: 06227 / 6052-57
E-Mail info@lamtec.de
Internet http://www.lamtec.de

Geschäftsführer
Dipl. Wirt. Ing. (FH), Dipl. Ing. (FH)
Hans-Jürgen Altendorf
Dipl. Ing. (BA) Ralf Lakatos
Dipl. Ing. (FH) Harald Weber
Dr.-Ing. Olaf Winne

Registergericht:
Mannheim GmbH HRB 351980
Mannheim KG: HRA 350589
USt. ID-Nr.: DE 811854931
Steuer-Nr.: 3207401305
Finanzamt Heidelberg

Bankverbindungen:
Volksbank Weschnitztal eG
BLZ 509 615 92, Kto.-Nr. 25 28 100
BIC: GENODE51FHO
IBAN: DE 71 5096 1592 0002 5261 00
Deutsche Bank AG Filiale Wiesloch
BLZ 672 700 24, Kto.-Nr. 09 0174400
BIC: DEUTDE33HAN
IBAN: DE 70 6727 0024 0090 1744 00



These values were determined assuming an average repair time MTTR = 8 hour, a diagnostic test interval $T_2 = 24$ hours and the following test intervals (proof test interval). The test intervals T_1 correspond to the service life of the components.

CPSD LT1 Lambda Transmitter: $T_1 = 10$ years

CPSE LS1 Lambda Probe:

- o Fuel = gas and oil: $T_1 = 5$ years
- o Fuel = heavy fuel oil: $T_1 = 3$ years
- o Fuel = special fuels: $T_1 = 1.5$ years

A review of the calculation, the safety-related evaluation, as well as their verification and documentation was confirmed by Luderer Engineering (<http://www.luderer.com/index.html>).

Leipzig, 23.02.2018

Dr.-Ing. Olaf Winne
Managing Director LAMTEC Meß- und Regeltechnik für Feuerungen GmbH & Co. KG
Managing Director LAMTEC Leipzig GmbH & Co. KG

LAMTEC Meß- und Regeltechnik
für Feuerungen GmbH & Co. KG
Wiesenstraße 6 (Gewerbegebiet Impex)
D-69190 Walldorf (Baden)
Tel.: 06227 / 6052-0, Fax: 06227 / 6052-57
E-Mail: info@lamtec.de
Internet: <http://www.lamtec.de>

Geschäftsführer
Dipl. Wirt.-Ing. (FH), Dipl. Ing. (FH)
Hans-Jürgen Altendorf
Dipl. Ing. (BA) Ralf Lakatos
Dipl. Ing. (FH) Harald Weber
Dr.-Ing. Olaf Winne

Registergericht:
Mannheim GMBH: HRB 351980
Mannheim KG: HRA 350589
USt. ID-Nr.: DE 811854931
Steuer-Nr. 3207401306
Finanzamt Heidelberg

Bankverbindungen:
Volksbank Weschnitztal eG
BLZ 508 615 92, Kto-Nr. 25 28 100
BIC: GENODE51FHO
IBAN: DE71 5096 1592 0002 5281 00
Deutsche Bank AG Filiale Wiesloch
BLZ 672 700 24, Kto-Nr. 09 0174400
BIC: DEUTDE33HAN
IBAN: DE70 6727 0024 0090 1744 00

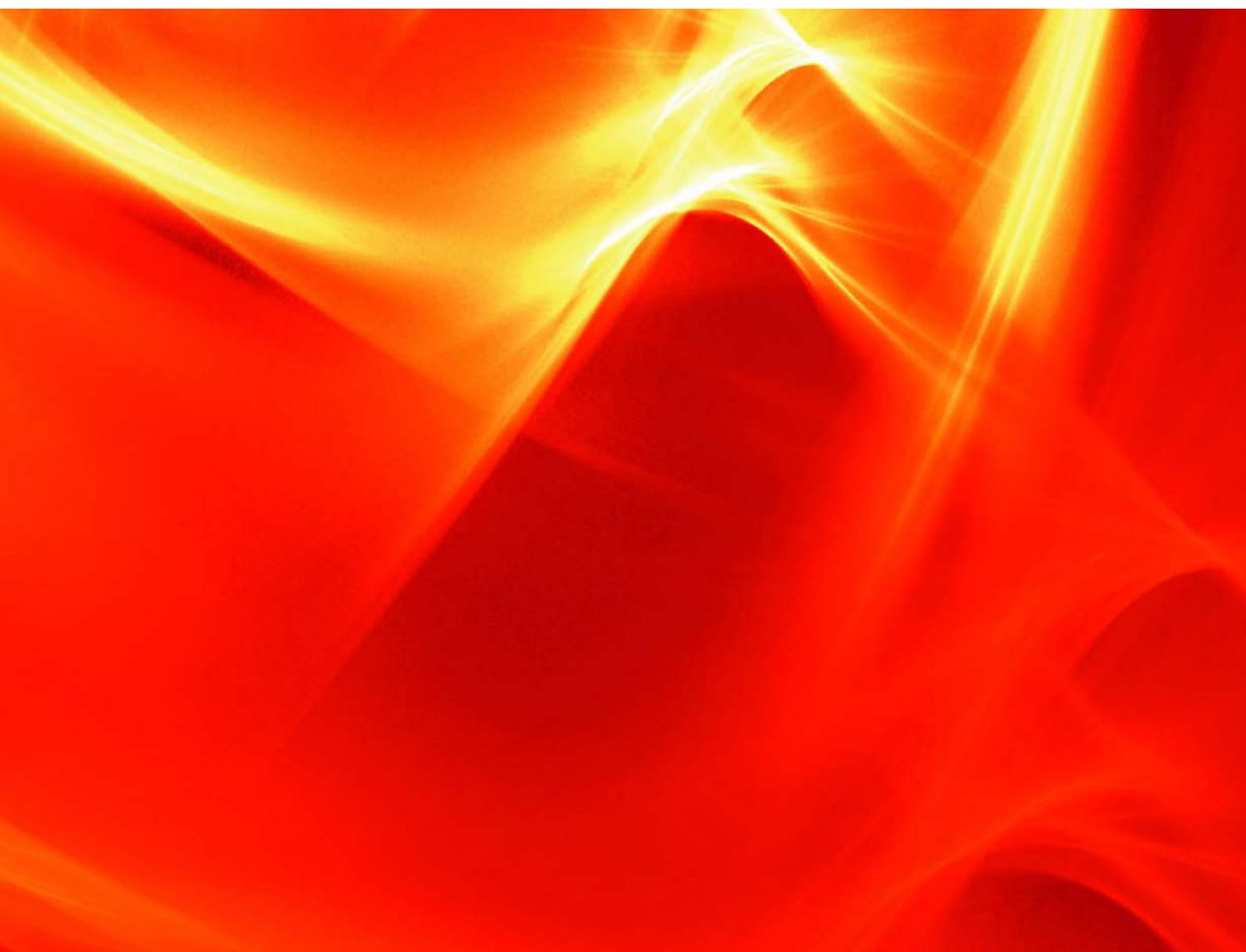

The information in this publication is subject to technical changes.



**LAMTEC Meß- und Regeltechnik
für Feuerungen GmbH & Co. KG**

Josef-Reiert-Straße 26
D-69190 Walldorf
Telefon: +49 (0) 6227 6052-0
Telefax: +49 (0) 6227 6052-57

info@lamtec.de
www.lamtec.de

